

Th1. STRUCTURAL DESIGN – I (SYLLABUS)

1.Working Stress Method (WSM)

- 1.1 Objectives of design and detailing. State the different methods of design of concrete structures.
- 1.2 Introduction to reinforced concrete, R.C. sections their behaviour, grades of concrete and steel. Permissible stresses, assumption in W.S.M.
- 1.3 Flexural design and analysis of single reinforced sections from first principles.
- 1.4 Concept of under reinforced, over reinforced and balanced sections.
- 1.5 Advantages and disadvantages of WSM, reasons for its obsolescence.

2.Philosophy of Limit State Method (LSM)

- 2.1 Definition, Advantages of LSM over WSM, IS code suggestions regarding design philosophy.
- 2.2 Types of limit states, partial safety factors for materials strength, characteristic strength, characteristic load, design load, loading on structure as per I.S. 875
- 2.3 Study of I.S specification regarding spacing of reinforcement in slab, cover to reinforcement in slab, beam column & footing, minimum reinforcement in slab, beam & column, lapping, anchorage, effective span for beam & slab.

3.Analysis and Design of Single and Double Reinforced Sections (LSM)

- 3.1 Limit state of collapse (flexure), Assumptions, Stress-Strain relationship for concrete and steel, neutral axis, stress block diagram and strain diagram for singly reinforced section.
- 3.2 Concept of under- reinforced, over-reinforced and limiting section, neutral axis co-efficient, limiting value of moment of resistance and limiting percentage of steel required for limiting singly R.C. section.
- 3.3 Analysis and design: determination of design constants, moment of resistance and area of steel for rectangular sections
- 3.4 Necessity of doubly reinforced section, design of doubly reinforced rectangular section

4.Shear, Bond and Development Length (LSM)

- 4.1 Nominal shear stress in R.C. section, design shear strength of concrete, maximum shear stress, design of shear reinforcement, minimum shear reinforcement, forms of shear reinforcement.
- 4.2 Bond and types of bond, bond stress, check for bond stress, development length in tension and compression, anchorage value for hooks 90° bend and 45° bend standards lapping of bars, check for development length.
- 4.3 Numerical problems on deciding whether shear reinforcement is required or not, check for adequacy of the section in shear. Design of shear reinforcement; Minimum shear reinforcement in beams (Explain through examples only).

5. Analysis and Design of T-Beam (LSM)

- 5.1 General features, advantages, effective width of flange as per IS: 456-2000 code provisions.
- 5.2 Analysis of singly reinforced T-Beam, strain diagram & stress diagram, depth of neutral axis, moment of resistance of T-beam section with neutral axis lying within the flange.
- 5.3 Simple numerical problems on deciding effective flange width. (Problems only on finding moment of resistance of T-beam section when N.A. lies within or up to the bottom of flange shall be asked in written examination)..

6. Analysis and Design of Slab and Stair case (LSM)

- 6.1 Design of simply supported one-way slabs for flexure check for deflection control and shear.
- 6.2 Design of one-way cantilever slabs and cantilevers chajjas for flexure check for deflection control and check for development length and shear.
- 6.3 Design of two-way simply supported slabs for flexure with corner free to lift.
- 6.4 Design of dog-legged staircase
- 6.5 Detailing of reinforcement in stairs spanning longitudinally.

7. Design of Axially loaded columns and Footings (LSM)

- 7.1 Assumptions in limit state of collapse- compression.
- 7.2 Definition and classification of columns, effective length of column. Specification for minimum reinforcement; cover, maximum reinforcement, number of bars in rectangular, square and circular sections, diameter and spacing of lateral ties.
- 7.3 Analysis and design of axially loaded short square, rectangular and circular columns (with lateral ties only).
- 7.4 Types of footing, Design of isolated square column footing of uniform thickness for flexure and shear.

Working Stress Method (WSM)

UNIT 8 INTRODUCTION TO WORKING STRESS METHOD AND FLEXURAL MECHANICS OF SINGLY REINFORCED RECTANGULAR SECTION

Structure

- 8.1 Introduction
 - Objectives
- 8.2 Basic Assumptions
- 8.3 Permissible Stresses in Concrete and Steel
- 8.4 Analytical Aspects of Design of Reinforcement Concrete Beams
- 8.5 Types of Singly Reinforced Rectangular Sections
- 8.6 Types of Problems in Singly Reinforced Rectangular Sections
- 8.7 Summary
- 8.8 Answers to SAQs

8.1 INTRODUCTION

R.C. structures or their elements may be designed by any of the three methods :

- (i) Limit State Method
- (ii) Working Stress Method, and
- (iii) Methods Based on Experimental Investigations

In this unit, Working Stress Method only shall be discussed. According to basic principles of design, structures or their elements must be safe and serviceable under design loads. Here design loads are actual loads (characteristic loads) on a structure. Safety of a structure is measured against permissible stresses due to design loads. These permissible stresses are 'Characteristic Strengths' divided by 'Factor of Safety' which are different for different materials. General design and detailing requirements including Limit State of Serviceability are the same as those applicable for Limit State Design except Redistribution of Moments in continuous beams and frames. Accordingly moments over supports for any assumed arrangement of loading, including the dead load moments may be increased or decreased by not more than 15%, provided that the modified moments over supports are used for calculation of the corresponding moments in the spans. *Thus, Working Stress Method of design of a structure or its elements is one in which under design loads the stresses developed are within permissible limits, and the detailing of concrete section as well as reinforcements are so as to meet the serviceability requirements.*

Objectives

Through this unit a student will be able to learn the following :

- Basics of Working Stress Method of Design
- Permissible Stresses in Concrete and Reinforcement used in design, and
- Analytical Aspect of Design of a structure and its elements under design loads

SAQ 1

- (i) Explain various methods of designing a R.C structure.
- (ii) Define
 - (a) Working Stress Method
 - (b) Factor of Safety
 - (c) Permissible Stress
 - (d) Design Loads in Working Stress Method

8.2 BASIC ASSUMPTIONS

All structures under design loads are analysed according to linear elastic theory. The design of different sections for providing adequate concrete and reinforcements are based on simplifying assumptions enumerated and discussed as follows :

- (i) A plane section of a structural element remains plane before and after bending
- (ii) The strain-stress ($\epsilon-\sigma$) relationship for concrete and steel under design loads (working or service loads) is linear.
- (iii) The tensile stress resistance of concrete in bending is zero, except specifically permitted, and
- (iv) The modular ratio, $m = \frac{280}{3\sigma_{cbc}}$

Assumptions (i), (ii) and (iii) need no explanation as assumptions (i) and (iii) have been explained in Limit State Method and assumption (ii) is self explanatory. According to assumption (iv), for example, for M 15 concrete the modular ratio,

$$m = \frac{280}{3\sigma_{cbc}} = \frac{280}{3 \times 5} = 18.18 \approx 19$$

As per Strength of Materials, generally, modular ratio, $m = \frac{E_s}{E_c}$. From code, modulus of

elasticity of steel, $E_s = 2 \times 10^5$ MPa and short term static modulus of elasticity of concrete,

$$E_c = 5700\sqrt{f_{ck}} = 5700\sqrt{15} = 227076 \text{ MPa and accordingly, } m = \frac{E_s}{E_c} = \frac{2 \times 10^5}{227076} = 9.06$$

This discrepancy is due to the fact that the value calculated as per assumption takes into account the *long-term* effects such as creep. The creep or any long-term effect goes on continuously deforming the elements during the whole life time of a R.C. structure and, in effect, lowers the modulus of elasticity of concrete. Thus *actual smaller* value of E_c results in higher modular ratio, m .

SAQ 2

- (i) Explain all the assumptions made in Working Stress Method.
- (ii) Why the prescribed value of modular ratio, m , of any grade of concrete is

much greater than those obtained by general formula, $m = \frac{E_s}{E_c}$?

Introduction to Working
Stress Method and
Flexural Mechanics of
Singly Reinforced
Rectangular Section

8.3 PERMISSIBLE STRESSES IN CONCRETE AND STEEL

Permissible stresses for various types of forces on structural concrete element is obtained by dividing the corresponding characteristic strength by appropriate 'Factor of Safety'. Accordingly, these stresses are mentioned in the following tables :

Table 8.1 : Permissible Direct Tension σ_t in R.C. Members in N/mm²

Grade of concrete	M 10	M 15	M 20	M 25	M 30	M 35	M 40
Permissible Tensile Stress, σ_t	1.2	2.0	2.8	3.2	3.6	4.0	4.4

The permissible stresses in direct tension are for members in which the reinforcement

alone takes all tension and the direct tension, f_t , is calculated as $f_t = \frac{F_t}{A_c + mA_{st}}$

Where F_t = total tension on the member minus pretension, if any, before concreting, and

A_c = cross sectional area of concrete excluding any finishing material and reinforcing steel

Table 8.2 Permissible Stress in Concrete in Bending & Direct Compression and in Bond.

Grade of Concrete	Permissible Stress in Compression		Permissible Stress in Bond (Average) for plain Bars in Tension
	Bending σ_{cbc}	Direct σ_{cc}	
M 10	3.0	2.5	---
M 15	5.0	4.0	0.6
M 20	7.0	5.0	0.8
M 25	8.5	6.0	0.9
M 30	10.0	8.0	1.0
M 35	11.5	9.0	1.1
M 40	13.0	10.0	1.2

* (i) The bond stress shall be increased by 25% for bars in compression, and

(ii) For deformed bars conforming to 15:1786 - 1979, the bond stress shall be increased by 40%

Table 8.3 Permissible Shear Stress in concrete without Shear Reinforcement

$\frac{100 A_s}{bd}$	Permissible Shear Stress in Concrete, τ_c N/mm ²					
	GRADE OF CONCRETE					
	M 15	M 20	M 25	M 30	M35	M 40
0.25	0.22	0.22	0.23	0.23	0.23	0.23
0.50	0.29	0.30	0.31	0.31	0.31	0.32
0.75	0.34	0.35	0.36	0.37	0.37	0.38
1.00	0.37	0.39	0.40	0.41	0.42	0.42
1.25	0.40	0.42	0.44	0.45	0.45	0.46
1.50	0.42	0.45	0.46	0.48	0.49	0.49
1.75	0.44	0.47	0.49	0.50	0.52	0.52
2.00	0.44	0.49	0.51	0.53	0.54	0.55
2.25	0.44	0.51	0.53	0.55	0.56	0.57
2.50	0.44	0.51	0.55	0.57	0.58	0.60
2.75	0.44	0.51	0.56	0.58	0.60	0.62
3.00 and above	0.44	0.51	0.57	0.60	0.62	0.63

Note : A_s = Area of longitudinal tensile reinforcement which continues at least 'd' beyond the section being considered except at supports where the full area of tension reinforcements may be used provided the detailing conforms to codal provisions.

Table 8.4 : Maximum Shear Stress with Shear Reinforcement, $\tau_{c, \max}$

Grade of concrete	M 15	M 20	M 25	M 30	M35	M 40
$\tau_{c, \max}$ (N/mm ²)	1.6	1.8	1.9	2.2	2.3	2.5

Table 8.5: Permissible Stresses in Steel Reinforcement

S. No.	Type of Stress in Reinforcement	Permissible Stresses in N/mm ²		
		Mild Steel Bars Conforming to Grade I of IS: 432 (Part I) 1966 or Deformed Mild Steel Bars Conforming to IS : 1139-1996	Medium Tensile Steel Conforming to IS 432 (Part I)- 1996 or Deformed Medium Tensile Steel Bars Conforming to IS : 1139-1996	High Yield Strength Deformed Bars Conforming to IS : 1139-1996 or IS : 1786 - 1979 (Grade Fe 415)
(1)	(2)	(3)	(4)	(5)
(i)	Tension (σ_{st} or σ_{sv})	140	Half the guaranteed yield stress subject to a maximum of 190	230
	(a) Up to and including 20 mm	130		
	(b) Over 20 mm			
(ii)	Compression in column bars (σ_{sc})	130	130	190
(iii)	Compression in bars in a beam or slab when the compressive resistance of the concrete is taken into account	The calculated compressive stress in the surrounding concrete multiplied by 1.5 times the modular ratio or σ_{sc} whichever is lower		
(iv)	Compression in bars in a beam or slab where the compressive resistance of the concrete is not taken into account			
	(a) Up to and including 20 mm	140	Half the guaranteed yield stress subject to a maximum of 190	
	(b) Over 20 mm	130		

- Note:**
- (i) 0.2% proof stress may be used for yield stress (f_y) for those steel for which there is no clearly defined yield point, and
 - (ii) When mild steel conforming to Grade II of IS 432 : (Part I) - 1966 is used, the permissible stresses shall be 90% of the permissible stresses of Grade of IS : 432 (Part) - 1966, but if the area of reinforcement have already been designed and detailed as per Grade of IS : 432 (Part I) - 1966 steel, the area of reinforcement shall be increased by 10% of that required for Grade I steel.

8.4 ANALYTICAL ASPECT OF DESIGN OF REINFORCED CONCRETE BEAMS

Bending moment causes internal strains and stresses perpendicular to the cross-sections of a beam (Figure 8.1(a)).

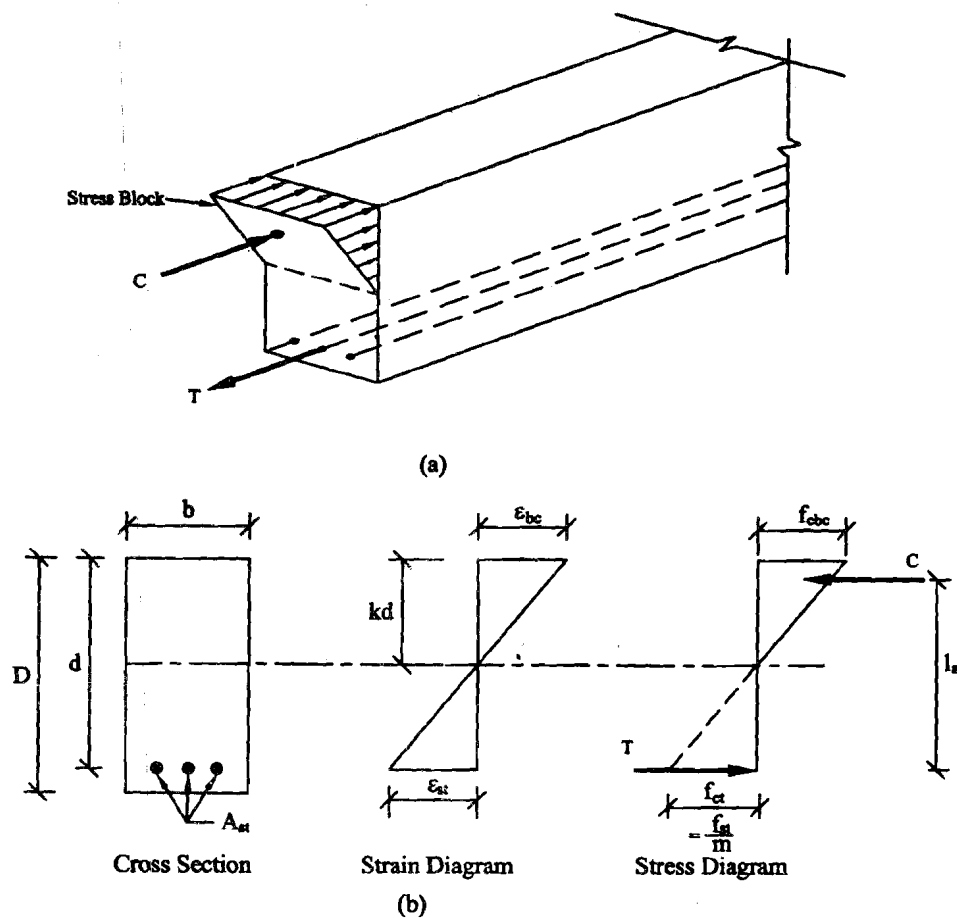

Figure 8.1 : Explaining Bending Mechanics of a Rectangular Beam

From the assumption (Basic Assumption(i)) that plane section remains plane before and after bending, the strain diagram is linear across the section (Figure 8.1(b)). If these strains are multiplied by the modulus of elasticity of concrete, E_c , the resulting stress diagram may be obtained (Basic Assumption (ii)). As tensile resistance of concrete is zero (Basic Assumption (iii)), a fictitious tensile stress in concrete, f_{ct} , (i.e. f_{ct} would have developed if concrete were resisting tensile stress at the level of reinforcing steel) is assumed to evaluate the tensile stress, f_{st} . The moment of resistance may then be calculated as follows :

(i) From *Stress Diagram*

$$\frac{f_{cbc}}{kd} = \frac{f_{ct}}{(d - kd)}$$

$$\text{or } f_{ct} = \frac{f_{cbc}}{kd} (d - kd) = \frac{f_{cbc} (1 - k)}{k}$$

Reinforced concrete being a composite material (i.e. perfect bond develops between concrete and steel), the strains at the level of centroid of steel both in concrete and steel are the same i.e.,

(ii) From *Strain Diagram* $\epsilon_{st} = \epsilon_{ct}$ where ϵ_{ct} = strain in concrete at the level of centroid of steel area

or
$$\frac{f_{st}}{E_{st}} = \frac{f_{ct}}{E_c}$$

or
$$f_{ct} = \frac{E_c}{E_{st}} f_{st} = \frac{f_{ct}}{m}$$

or
$$f_{st} = m f_{ct} \text{ where } m = \frac{280}{3\sigma_{cbc}} \text{ (Basic Assumption iv)}$$

(iii) From *Force Equilibrium*

$$C - T = 0$$

or
$$C = T$$

or
$$1/2 f_{cbc} bkd = f_{st} A_{st}$$

(iv) From *Moment Equilibrium*

Applied Bending Moment = Resisting Bending Moment

or
$$M_{\text{applied}} = M_R = C.l_a = T.l_a$$

or
$$M_R = \frac{1}{2} f_{cbc} bkd \left(d - \frac{kd}{3} \right) = f_{st} A_{st} \left(d - \frac{kd}{3} \right)$$

$$= \frac{1}{2} f_{cbc} k \left(1 - \frac{k}{3} \right) b d^2 = f_{st} A_{st} \left(1 - \frac{k}{3} \right) d$$

$$= \frac{1}{2} f_{cbc} k j b d^2 = f_{st} A_{st} j d \quad \text{where } j = \left(1 - \frac{k}{3} \right)$$

$$= R b d^2 = f_{st} A_{st} j d \quad \text{where } R = \frac{1}{2} f_{cbc} k j \quad \dots (8.1)$$

SAQ 3Derive from the basic principles the Moment of Resistance, M_R , of a singly reinforced concrete section.

**8.5 TYPES OF SINGLY REINFORCED
RECTANGULAR SECTIONS**

Based on fundamentals of analysis in the above section, a singly reinforced rectangular section may be put in any of the three categories :

- (i) a Balanced Section
- (ii) an Under-Reinforced Section, and
- (iii) an Over-Reinforced Section

(i) *Balanced Section*

A section is balanced when the extreme fibre of concrete in compression and the tensile steel reach their respective permissible stresses simultaneously under applied bending moment

Under applied bending moment, M_{applied} , the maximum stress in concrete in compression and tensile stress in steel are their respective permissible values, σ_{cbc} and σ_{st} (Figure 8.2).

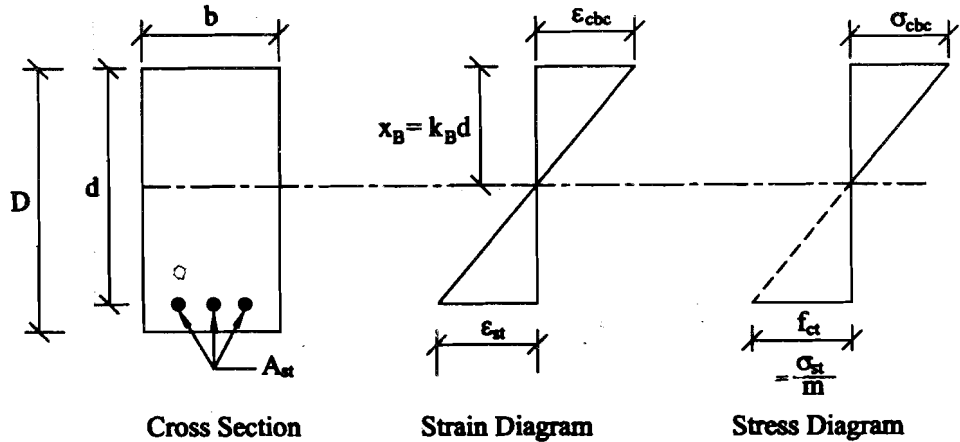

Figure 8.2 : A Balanced Section

Neutral-axis depth in this case is denoted by $k_B d$ or x_B where k_B = coefficient for n.a. depth for balanced section.

Therefore, Moment of Resistance

$$M_R = \frac{1}{2} \sigma_{cbc} k_B j_B b d^2 = \sigma_{st} A_{st} j d$$

or $M_R = R_B b d^2 \dots (8.2)$

(ii) *Under-Reinforced Section*

As the name suggests an under-reinforced section is one in which the area of tensile reinforcement provided is less than that required for balanced section.

Let a cross section of reinforced concrete may be taken in which the area of tensile steel is less than that required to make it a balanced section (Figure 8.3). If applied moment is increased gradually on such section, the permissible tensile stress in steel will reach first since $A_{st} < A_{stB}$, and at this stage the stress in concrete will be $f_{cbc} < \sigma_{cbc}$ (Figure 8.3(d)).

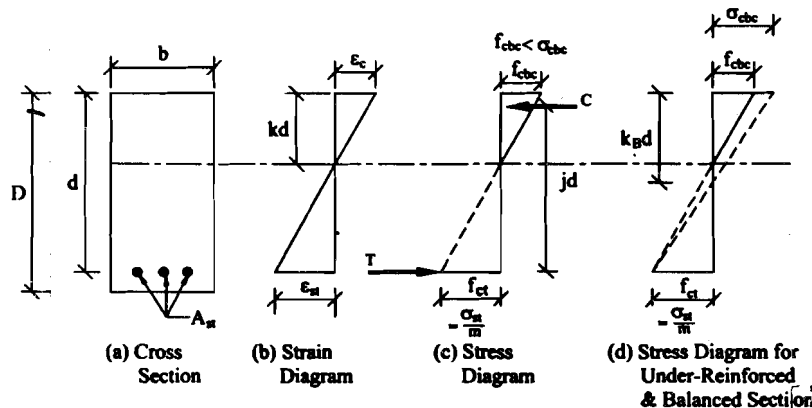

Figure 8.3 : An Under Reinforced Section

The n.a. depth may be determined by equating moment of area of concrete in compression and equivalent area of tensile steel in terms of concrete about n.a.

$$b.k.d.\frac{kd}{2} = mA_{st}(d - kd)$$

The resulting value of $kd < k_b d$ (Fig : 8.3 d) and hence

$$M_R = A_{st}\sigma_{st}\left(d - \frac{kd}{3}\right) = A_{st}\sigma_{st}jd \text{ (Fig : 8.3 c)}$$

(iii) **Over Reinforced Section**

An over Reinforced Section is one in which the tensile reinforcing steel area is more that required for a balanced section.

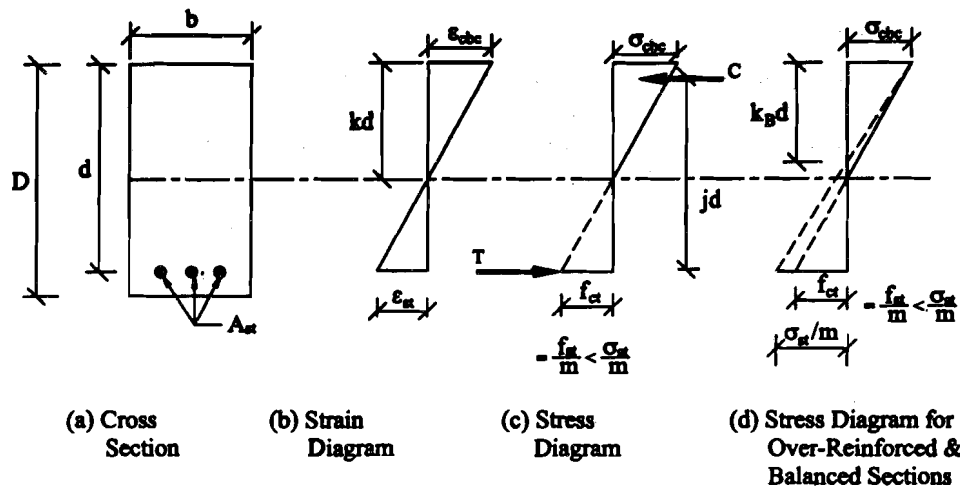

Figure 8.4 : An Over-Reinforced Section

As $A_{st} > A_{stB}$, the permissible stress in concrete (σ_{cbc}) will reach first due to gradual application of bending moment resulting in $kd > k_b d$ (Figure 8.4 d), the value of kd may be obtained by equating moment of area of concrete in compression and equivalent area of tensile steel in terms of concrete about n.a.

$$b.k.d.\frac{kd}{2} = mA_{st}(d - kd)$$

Hence moment of resistance

$$M_R = \frac{1}{2}\sigma_{cbc}b.k.d.\left(d - \frac{kd}{3}\right) \\ = \frac{1}{2}\sigma_{cbc}kj.bd^2$$

SAQ 4

- (i) How many types of singly reinforced sections can be had based on percentage of reinforcement provided?
- (ii) Define and explain Balanced Section
- (iii) Explain the meaning of a Under-Reinforced Section,
- (iv) Is Moment of Resistance of an over-reinforced section is more than that for a Balanced Section, if so, explain why ?

8.6 TYPES OF PROBLEMS IN SINGLY REINFORCED RECTANGULAR SECTIONS

Four types of problems may be encountered :

- Type I : To determine M_R and w for a given cross section
- Type II : To determine maximum compressive stress in concrete (f_{cbc}) and tensile stress in steel (f_{st}) for a given cross section and $M_{applied}$.
- Type III : To determine M_{RB} and A_{stB} when *concrete* cross section is only given, and
- Type IV : To design a singly reinforced section for a given bending moment

The above mentioned types of problems have been given and illustrated with examples given below.

Example 8.1

Determine moment of resistance and uniformly distributed super-imposed load carried by a simply supported singly reinforced R.C. beam having effective span 5m and a cross section of 300×555 ($b \times d$) reinforced with $5 \phi 20$. Use M 15 concrete and Fe 250 steel.

Solution

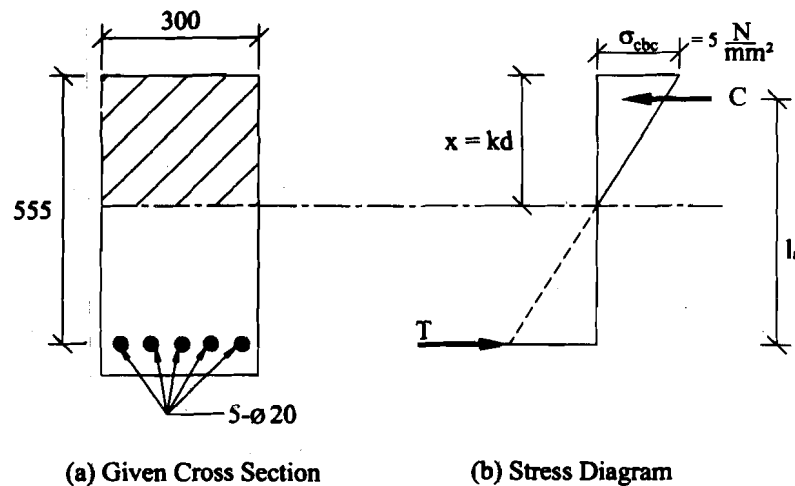

Figure 8.5 : Showing Cross-Section and Stress Diagram of the Beam

Equating moment of area of concrete in compression and equivalent area of tensile steel in terms of concrete about n.a. (Figure 8.5(a)).

$$b \frac{x^2}{2} = m A_{st} (d - x)$$

Here $m = \frac{280}{3\sigma_{cbc}} = \frac{280}{3 \times 5} \approx 19$ and

$$A_{st} = 5 \times \frac{\pi}{4} \times 20^2 = 1570.8 \text{ mm}^2$$

or $\frac{300x^2}{2} = 19 \times 1570.8(555 - x)$

$$\text{or } x^2 + 198.97x - 110427.24$$

$$\text{or } x = 247.4$$

The value of x_B is next determined to compare it with x and to know the type of the section.

$$x_B = k_B d = \frac{1}{1 + \frac{\sigma_{st}}{m\sigma_{cbc}}} d = \frac{1}{1 + \frac{140}{19 \times 5}} = 0.4d$$

$x_B = 0.4 \times 555 = 222 < 247.4$ Hence the section is over-reinforced (Figure 8.4(d)) and the stress distribution across the section is as shown is Figure 8.5(b)

$$\begin{aligned} \text{Thus } M_R &= \frac{1}{2} \sigma_{cbc} b \cdot x \cdot \left(d - \frac{x}{3} \right) \\ &= \frac{1}{2} \times 5 \times 300 \times 247.4 \times \left(555 - \frac{247.4}{3} \right) \times 10^{-6} \\ &= 87.68 \text{ kNm Ans} \end{aligned}$$

As the beam is simply-supported with a u.d.L. (w) over the whole span,

$$M_R = \frac{wl_{ef}^2}{8}$$

$$\text{or } 87.68 \times 10^6 = \frac{w5^2}{8}$$

$$\text{or } w = 28.05 \text{ kN/m (including self weight)}$$

$$\text{Self weight} = 0.3 \times 0.6 \times 1 \times 25 = 4.5 \text{ kN/m (taking 45 as effective cover)}$$

$$\begin{aligned} \therefore \text{ Super-imposed load } w_s &= 28.05 - 4.5 \\ &= 23.55 \text{ kN/m Ans} \end{aligned}$$

Example 8.2

Calculate the maximum compressive stress in concrete and tensile stress in reinforcing steel for a R.C. beam of 3.6m effective span having a cross section of 300×600 ($b \times D$) with $4\phi 20$ and clear concrete cover of 25. The beam is loaded with a super-imposed u.d.l. of 80 kN. Use $m = 19$

Solution

$$\begin{aligned} \text{Total u.d.l.} &= \text{Super-imposed load} + \text{self weight} \\ &= 80 + 0.3 \times 0.6 \times 3.6 \times 25 = 96.2 \text{ kN} \end{aligned}$$

$$M_{\max} = \frac{WL}{8} = \frac{96.2 \times 3.6}{8} = 43.29 \text{ kNm}$$

Equating moment of areas of concrete in compression and transformed area of tensile steel about n.a.

$$\frac{bx^2}{2} = mA_{st}(d-x)$$

Working Stress Method

$$\text{or } \frac{300 \times x^2}{2} = 19 \times 1256.6(565 - x)$$

$$\text{or } x^2 + 159.1x - 89930.67 = 0$$

$$\text{or } x = 230.68$$

The maximum stress in concrete and steel may now be evaluated as under :

$$M = \frac{1}{2} f_{cbc} b x \left(d - \frac{x}{3} \right)$$

$$\text{or } 43.29 \times 10^6 = \frac{1}{2} f_{cbc} \times 300 \times 230.68 \left(565 - \frac{230.68}{3} \right)$$

$$\text{or } f_{cbc} = 2.56 \text{ N/mm}^2 \text{ Ans}$$

Again

$$M = f_{st} A_{st} \left(d - \frac{x}{3} \right)$$

$$\text{or } 43.29 \times 10^6 = f_{st} \times 1256.6 \left(565 - \frac{230.68}{3} \right)$$

$$\text{or } f_{st} = 70.58 \text{ N/mm}^2 \text{ Ans}$$

Example 8.3

Determine moment of resistance and the area of tensile steel required for a section of R.C. beam of 300×550 ($b \times d$). Use M 15 concrete and Fe 415 steel.

Solution

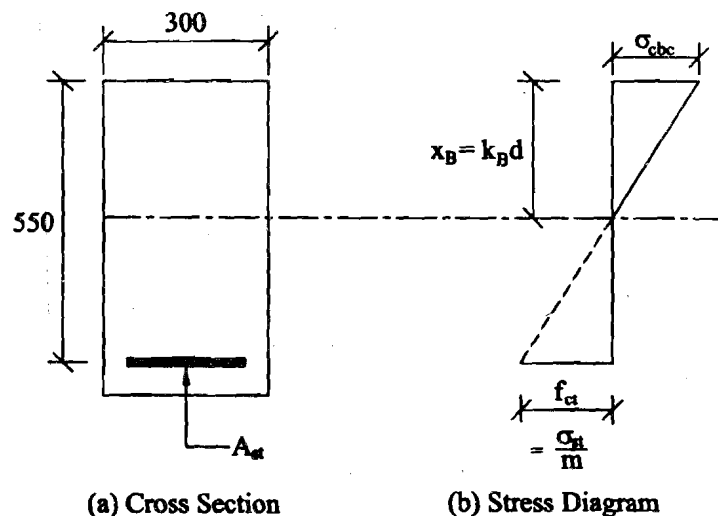

Figure 8.6 : Showing Cross-Section and the Stress Diagram for Balanced Section

As M_R and A_{st} are to be determined for balanced section, the value of k_B is first determined Figure 8.6.

$$k_B = \frac{1}{1 + \frac{\sigma_{st}}{m \sigma_{cbc}}} = \frac{1}{1 + \frac{230}{19 \times 5}} = 0.292$$

$$\text{where } m = \frac{280}{3 \times \sigma_{cbc}} = \frac{280}{3 \times 5} \approx 19$$

$$j_B = 1 - \frac{k_B}{3} = 1 - \frac{0.292}{3} = 0.903$$

$$R_B = \frac{1}{2} \sigma_{cbc} j_B = \frac{1}{2} \times 5 \times 0.292 \times 0.903$$

$$= 0.659$$

$$\therefore M_R = M_B = R_B b d^2 = 0.659 \times 300 \times 555^2 \times 10^6$$

$$= 59.86 \text{ kNm Ans}$$

$$A_{st} = \frac{M_b}{\sigma_{st} j_B d} = \frac{59.86 \times 10^6}{230 \times 0.903 \times 550} = 524 \text{ mm}^2 \text{ Ans}$$

Example 8.4

Design for flexure only a R.C. beam of 5m clear span supported on two walls of 300 thickness and carrying a super-imposed load of 20 kN/m. Use M 15 concrete and Fe 415 steel.

Solution**Design coefficients**

$$m = \frac{280}{3 \sigma_{cbc}} = \frac{280}{3 \times 5} \approx 19$$

For balanced section

$$k_B = \frac{1}{1 + \frac{\sigma_{st}}{m \sigma_{cbc}}} = \frac{1}{1 + \frac{230}{19 \times 5}} = 0.292$$

$$j_B = 1 - \frac{k_B}{3} = 1 - \frac{0.292}{3} = 0.903$$

$$R_B = \frac{1}{2} \sigma_{cbc} k_B j_B = \frac{1}{2} \times 5 \times 0.292 \times 0.903 = 0.66$$

Depth (D)

(i) *Thumb Rule*

$$D \text{ lying between } \frac{l_{ef}}{10} \text{ to } \frac{l_{ef}}{20}. \text{ Therefore taking } D = \frac{l_{ef}}{12} = \frac{5.3 \times 10^3}{12} = 441.67$$

(where l_{ef} = c/c distance between supports = 5.3m)

(ii) *From Deflection criteria*

$$d \leq \frac{l_{ef}}{K_B K_1 K_2 K_3}$$

$K_B = 20$ for simply supported beam

Working Stress Method

$$p_{tB} \% = \frac{\sigma_{cbc} k_B}{2\sigma_{st}} \times 100 = \frac{5 \times 0.292}{2 \times 230} \times 100 = 0.32\%$$

and correspondingly $K_1 = 1.4$

$$K_2 = K_3 = 1$$

Substituting these values in the above equation

$$d \leq \frac{5.3 \times 10^3}{20 \times 1.4 \times 1 \times 1} (= 189.29)$$

Taking $D = 450$ and $d = 415$

and taking b (between $D/3$ to $2D/3$) = 225

l_{ef} is lesser of

(i) c/c distance between supports
 $= 5 \text{ m} + 0.3 \text{ m} = 5.3 \text{ m}$, and

(ii) clear span + d
 $= 5 \text{ m} + 0.415 \text{ m} = 5.415 \text{ m}$

Thus $l_{ef} = 5.3 \text{ m}$

(iii) From moment of resistance consideration

Loads

Self weight = $0.225 \times 0.45 \times 1 \times 25 = 2.53 \text{ kN/m}$

Super imposed load = 20.00 kN/m

Total load $w = 22.53 \text{ kN/m}$

$$M_{\max} = \frac{wl_{ef}^2}{8} = \frac{22.53 \times 5.3^2}{8} = 79.1 \text{ kNm}$$

$$\therefore d = \sqrt{\frac{M}{R_B b}} = \sqrt{\frac{79.1 \times 10^6}{0.66 \times 225}} = 729.84 \gg 415$$

Taking $D = 775$, $d = 730$ and $b = 350$

Loads

Self weight = $0.775 \times 0.35 \times 1 \times 25 = 6.78 \text{ kN/m}$

Super imposed load = 20.00 kN/m

Total load $w = 26.78 \text{ kN/m}$

$$M_{\max} = \frac{wl_{ef}^2}{8} = \frac{26.78 \times 5.3^2}{8} = 94.035 \text{ kNm}$$

$$\therefore d = \sqrt{\frac{M}{R_B b}} = \sqrt{\frac{94.035 \times 10^6}{0.66 \times 350}} = 638 < 730 \text{ (to be provided)}$$

Check for Lateral Stability

Assuming the lateral restraints have been provided at the centres of supports

(l_{ef}) = 5.3 m ($60 b = 60 \times 0.35 = 21 \text{ m}$) and

$$(l_{ef} = 5.3m) \left\{ \frac{250b^2}{d} = \frac{250 \times 0.35^2}{0.73} = 41.95m \right\}$$

Hence provided $D = 775$; $d = 730$ and $b = 350$

A_{st}

$$A_{st} = \frac{M}{\sigma_{st} j_B d} = \frac{9.4035 \times 10^6}{230 \times 0.903 \times 730} = 619.98 \text{ mm}^2$$

$$\frac{A_{st, \min}}{bd} = \frac{0.85}{f_y}$$

$$\text{or } A_{st, \min} = \frac{0.85 \times 350 \times 730}{415} = 523.31 \text{ mm}^2 < 619.98 \text{ mm}^2$$

Hence provided 4#16 ($A_{st} = 804 \text{ mm}^2 > 619.98 \text{ mm}^2$)

Side Face Reinforcement

$$0.1\% \text{ of total Cross Sectional Area of concrete} = \frac{0.1 \times 350 \times 775}{100} = 271.25 \text{ mm}^2$$

Provided 4#10 ($A_s = 314.16 \text{ mm}^2 > 271.25 \text{ mm}^2$)

The designed cross section is shown in Figure 8.7.

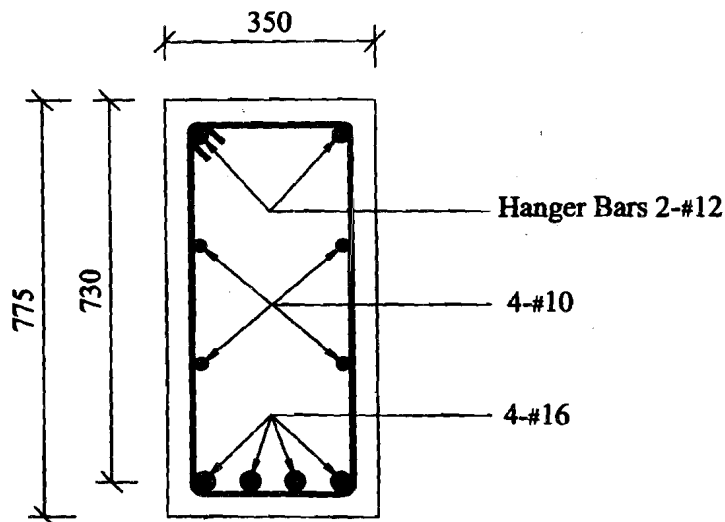

Figure 8.7 : Cross-Section of the Designed Beam

SAQ 5

- (i) Calculate the Moment of Resistance M_R , of a singly reinforced R.C. Section $b \times d = 250 \times 550$ reinforced with 3 # 20. Use M 20 concrete and Fe 415 steel.
- (ii) A singly reinforced cross section, $b \times d = 250 \times 400$ is reinforced with 3 # 20. Determine maximum compressive stress in concrete and tensile stress in steel if a bending moment 30 kNm is applied on it. Use M 15 concrete and Fe 415 steel.
- (iii) Determine Moment of Resistance, M_R and percentage of tensile steel $p_t\%$, for a concrete section $b \times d = 300 \times 500$ taking M 15 concrete and Fe 250 steel.

- (iv) Design for flexure only a R.C. simply supported beam for the following data :

Clear Span	= 5.6m
Super imposed Dead Load	= 10 kN/m
Live Load	= 15 kN/m
Width of Supports	= 375
Use M 15 concrete and Fe 415 steel	

8.7 SUMMARY

Basic principles involved in the analysis and design for flexure by Working Stress Method have been explained. Assumptions made to simplify the analysis & design have been enunciated and discussed. Flexure Mechanics of R.C. Sections have been explained through derivation of basic equations and parameters of simple singly reinforced sections from the given data. Examples have been solved to illustrate the above mentioned facts.

8.8 ANSWERS TO SAQs

SAQ 1

- (i) Refer text 8.1
- (ii) Refer text 8.1

SAQ 2

- (i) Refer text 8.2
- (ii) Refer text 8.2

SAQ 3

Refer text 8.4

SAQ 4

- (i) Refer text 8.5
- (ii) Refer text 8.5
- (iii) Refer text 8.5
- (iv) Refer text 8.5

SAQ 5

- (i) 90.27 kNm
- (ii) $f_{cbc} = 3.95 \text{ N/mm}^2$ and $f_{st} = 93.45 \text{ N/mm}^2$
- (iii) $M_r = 65.54 \text{ kNm}$, $p_t\% = 0.71$
- (iv) Provide $b \times d = 400 \times 760$ reinforced with 4 # 16 ($A_{st} = 804 \text{ mm}^2 > \text{reqd. } 622.63 \text{ mm}^2$) and side face reinforcement of 4 # 10.

Introduction to Working
Stress Method and
Flexural Mechanics of
Singly Reinforced
Rectangular Section

Limit State Method (LSM)

Introduction

Reinforced concrete, as a composite material, has occupied a special place in the modern construction of different types of structures due to its several advantages. Due to its flexibility in form and superiority in performance, it has replaced, to a large extent, the earlier materials like stone, timber and steel. Further, architect's scope and imaginations have widened to a great extent due to its mouldability and monolithicity. Thus, it has helped the architects and engineers to build several attractive shell forms and other curved structures. However, its role in several straight line structural forms like multistoried frames, bridges, foundations etc. is enormous.

Concrete

Concrete is a product obtained artificially by hardening of the mixture of cement, sand, gravel and water in predetermined proportions.

Depending on the quality and proportions of the ingredients used in the mix the properties of concrete vary almost as widely as different kinds of stones.

Concrete has enough strength in compression, but has little strength in tension. Due to this, concrete is weak in bending, shear and torsion. Hence the use of plain concrete is limited applications where great compressive strength and weight are the principal requirements and where tensile stresses are either totally absent or are extremely low.

Properties of Concrete

The important properties of concrete, which govern the design of concrete mix are as follows

(i) Weight

The unit weights of plain concrete and reinforced concrete made with sand, gravel of crushed natural stone aggregate may be taken as 24 KN/m^3 and 25 KN/m^3 respectively.

(ii) Compressive Strength

With given properties of aggregate the compressive strength of concrete depends primarily on age, cement content and the water cement ratio are given Table 2 of IS 456:2000. Characteristic strength are based on the strength at 28 days. The strength at 7 days is about two-thirds of that at 28 days with ordinary portland cement and generally good indicator of strength likely to be obtained.

(iii) Increase in strength with age

There is normally gain of strength beyond 28 days. The quantum of increase depends upon the grade and type of cement curing and environmental conditions etc.

(iv) Tensile strength of concrete

The flexure and split tensile strengths of various concrete are given in IS 516:1959 and IS 5816:1970 respectively when the designer wishes to use an estimate of the tensile strength from compressive strength, the following formula can be used

$$\text{Flexural strength, } f_{cr}=0.7\sqrt{f_{ck}} \text{ N/mm}^2$$

(v) Elastic Deformation

The modulus of elasticity is primarily influenced by the elastic properties of the aggregate and to lesser extent on the conditions of curing and age of the concrete, the mix proportions and the type of cement. The modulus of elasticity is normally related to the compressive characteristic strength of concrete

$$E_c=5000\sqrt{f_{ck}} \text{ N/mm}^2$$

Where E_c = the short-term static modulus of elasticity in N/mm^2

f_{ck} =characteristic cube strength of concrete in N/mm^2

(vi) Shrinkage of concrete

Shrinkage is the time dependent deformation, generally compressive in nature. The constituents of concrete, size of the member and environmental conditions are the factors on which the total shrinkage of concrete depends. However, the total shrinkage of concrete is most influenced by the total amount of water present in the concrete at the time of mixing for a given humidity and temperature. The cement content, however, influences the total shrinkage of concrete to a lesser extent. The approximate value of the total shrinkage strain for design is taken as 0.0003 in the absence of test data (cl. 6.2.4.1).

(vii) Creep of concrete

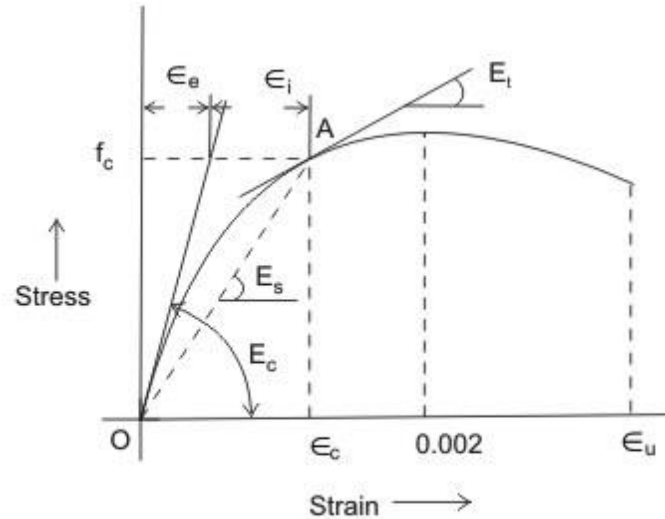

Figure 1.1: Stress-strain curve of concrete

Creep is another time dependent deformation of concrete by which it continues to deform, usually under compressive stress. The creep strains recover partly when the stresses are released. Figure 1.2.2 shows the creep recovery in two parts. The elastic recovery is immediate and the creep recovery is slow in nature.

Thus, the long term deflection will be added to the short term deflection to get the total deflection of the structure. Accordingly, the long term modulus E_{ce} or the effective modulus of concrete will be needed to include the effect of creep due to permanent loads. The relationship between E_{ce} and E_c is obtained as follows:

$$\varepsilon_c = f_c / E_c$$

Where, ε_c = short term strain at the age of loading at a stress value of f_c

$$\theta = \text{creep co-efficient} = \frac{\varepsilon_{cr}}{\varepsilon_c}$$

ε_{cr} = ultimate creep strain

The values of θ on 7th, 28th and 365th day of loading are 2.2, 1.6 and 1.1 respectively.

$$\text{Then the total strain} = \varepsilon_c + \varepsilon_{cr} = \frac{f_c}{E_{ce}}$$

Where, E_{ce} = effective modulus of concrete.

From the above Equation, we have

$$E_{ce} = \frac{f_c}{\varepsilon_c + \varepsilon_{cr}} = \frac{\varepsilon_c}{\varepsilon_c + \varepsilon_{cr}} = \frac{E_c}{1 + \theta}$$

The effective modulus of E_{ce} of concrete is used only in the calculation of creep deflection.

It is seen that the value of creep coefficient θ is reducing with the age of concrete at loading. It may also be noted that the ultimate creep strain ε_{cr} does not include short term strain ε_c . The creep of concrete is influenced by

- Properties of concrete
- Water/cement ratio
- Humidity and temperature of curing
- Humidity during the period of use
- Age of concrete at first loading
- Magnitude of stress and its duration
- Surface-volume ratio of the member

(f) Thermal expansion of concrete

The knowledge of thermal expansion of concrete is very important as it is prepared and remains in service at a wide range of temperature in different countries having very hot or cold climates. Moreover, concrete will be having its effect of high temperature during fire. The coefficient of thermal expansion depends on the nature of cement, aggregate, cement content, relative humidity and size of the section. IS 456 stipulates (cl. 6.2.6) the values of coefficient of thermal expansion for concrete / °C for different types of aggregate.

Workability and Durability of Concrete

Workability and durability of concrete are important properties to be considered. The relevant issues are discussed in the following:

The workability of a concrete mix gives a measure of the ease with which fresh concrete can be placed and compacted. The concrete should flow readily into the form and go around and cover the reinforcement, the mix should retain its consistency and the aggregates should not segregate. A mix with high workability is needed where sections are thin and/or reinforcement is complicated and congested. The main factor affecting workability is the water content of the mix. Admixtures will increase workability but may reduce strength. The

size of aggregate, its grading and shape, the ratio of coarse to fine aggregate and the aggregate-to-cement ratio also affect workability to some degree.

Measurement of workability

(a) Slump test

The fresh concrete is tamped into a standard cone which is lifted off after filling and the slump is measured. The slump is 25–50 mm for low workability, 50–100 mm for medium workability and 100–175 mm for high workability. Normal reinforced concrete requires fresh concrete of medium workability. The slump test is the usual workability test specified.

(b) Compacting factor test

The degree of compaction achieved by a standard amount of work is measured. The apparatus consists of two conical hoppers placed over one another and over a cylinder. The upper hopper is filled with fresh concrete which is then dropped into the second hopper and into the cylinder which is struck off flush. The compacting factor is the ratio of the weight of concrete in the cylinder to the weight of an equal volume of fully compacted concrete. The compacting factor for concrete of medium workability is about 0.9.

Durability of concrete

A durable concrete performs satisfactorily in the working environment during its anticipated exposure conditions during service. The durable concrete should have low permeability with adequate cement content, sufficient low free water/cement ratio and ensured complete compaction of concrete by adequate curing. For more information, please refer to cl. 8 of IS 456.

Design mix and nominal mix concrete

In design mix, the proportions of cement, aggregates (sand and gravel), water and mineral admixtures, if any, are actually designed, while in nominal mix, the proportions are nominally adopted. The design mix concrete is preferred to the nominal mix as the former results in the grade of concrete having the specified workability and characteristic strength (vide cl. 9 of IS 456).

Batching

Mass and volume are the two types of batching for measuring cement, sand, coarse aggregates, admixtures and water. Coarse aggregates may be gravel, grade stone chips or other man made aggregates. The quantities of cement, sand, coarse aggregates and solid admixtures shall be measured by mass. Liquid admixtures and water are measured either by volume or by mass (cl. 10 of IS 456).

Properties of reinforcing steel

Steel reinforcement used in reinforced concrete may be of the following types

- (a) 1. Mild steel bars conforming to IS 432 (part-I)
 - 2. Hot rolled mild steel conforming to IS 1139
 - (b) 1. Medium tensile steel conforming to IS 432 (part-I)
 - 2. Hot rolled medium tensile steel.
 - (c) 1. Hot rolled High Yield Strength Deformed (HYSD) steel conforming to IS 1139.
 - 2. Cold-worked steel HYSD bars steel conforming to IS 1786.
 - (d) 1. Hard drawn steel wire fabric conforming to IS 1566.
 - 2. Rolled steel made from structural steel conforming to Is 226.
1. the most important characteristic of a reinforcing bar is its stress strain curve and the important property yield stress or 0.2% proof stress, as the case may be.
 2. The modulus of elasticity E for these steel is $2 \times 10^5 \text{ N/mm}^2$.
 3. Mild steel bars have yield strength of 250 N/mm^2 and hence it is known as Fe 250.
 4. HYSD bars may be hot rolled high yield strength bars or cold rolled steel high strength deformed bars. The latter are also known as cold twisted deformed bars or Tor steel and are available in different grades
 - i) Fe 415 ii) 500 iii) Fe 550 having 0.2% proof stress as 415 N/mm^2 , 500 N/mm^2 and 550 N/mm^2
 5. The reinforcing bars should have sufficient % of elongation.
 6. Its coefficients of thermal expansion should be more or less equal to the cement concrete.

Stress-strain curves for reinforcement

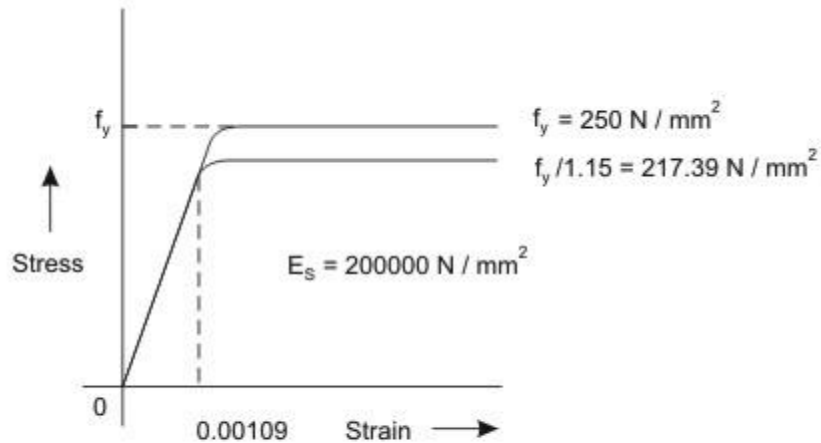

Figure1.2: Stress-strain curve for Mild steel (idealised) (Fe 250) with definite yield point

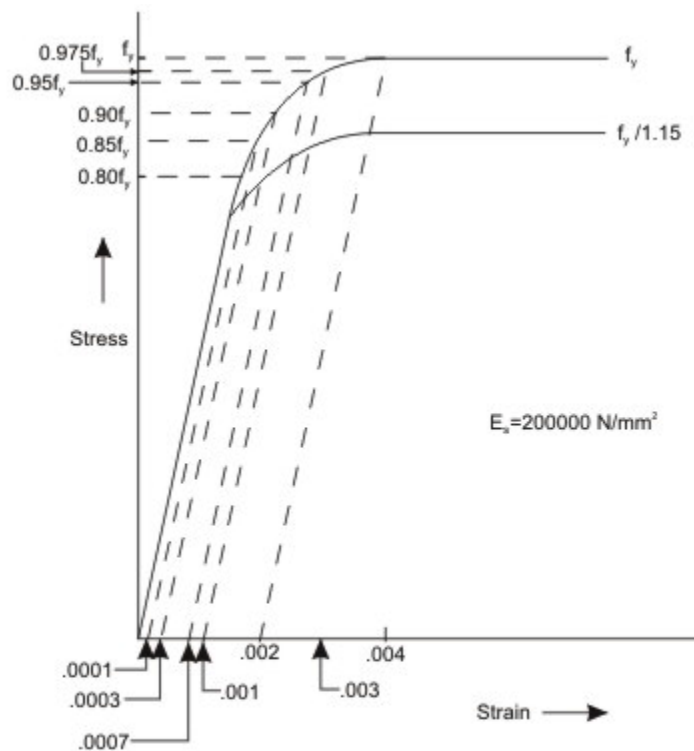

Figure1.3: Stress-strain curve for cold worked deform bar

Figures 1.2 and 1.3 show the representative stress-strain curves for steel having definite yield point and not having definite yield point, respectively. The characteristic yield strength f_y of steel is assumed as the minimum yield stress or 0.2 per cent of proof stress for steel having no definite yield point. The modulus of elasticity of steel is taken to be 200000 N/mm^2 .

For mild steel, the stress is proportional to the strain up to the yield point. Thereafter, post yield strain increases faster while the stress is assumed to remain at constant value of f_y .

For cold-worked bars (Fig. 1.3), the stress is proportional to the strain up to a stress of $0.8 f_y$.

Thereafter, the inelastic curve is defined as given below:

Stress	Inelastic strain
$0.80 f_y$	Nil
$0.85 f_y$	0.0001
$0.90 f_y$	0.0003
$0.95 f_y$	0.0007
$0.975 f_y$	0.0010
$1.00 f_y$	0.0020

Linear interpolation is to be done for intermediate values. The two grades of cold-worked bars used as steel reinforcement are Fe 415 and Fe 500 with the values of f_y as 415 N/mm² and 500 N/mm², respectively.

Method of RCC design

A reinforced concrete structure should be designed to satisfy the following criteria-

- i) Adequate safety, in items stiffness and durability
- iii) Reasonable economy.

The following design methods are used for the design of RCC Structures.

- a) The working stress method (WSM)
- b) The ultimate load method (ULM)
- c) The limit state method (LSM)

Working Stress Method (WSM)

This method is based on linear elastic theory or the classical elastic theory. This method ensured adequate safety by suitably restricting the stress in the materials (i.e. concrete and steel) induced by the expected working loads on the structures. The assumption of linear elastic behaviour considered justifiable since the specified permissible stresses are kept well below the ultimate strength of the material. The ratio of yield stress of the steel reinforcement or the cube strength of the concrete to the corresponding permissible or working stress is usually called factor of safety.

The WSM uses a factor of safety of about 3 with respect to the cube strength of concrete and a factor of safety of about 1.8 with respect to the yield strength of steel.

Ultimate load method (ULM)

The method is based on the ultimate strength of reinforced concrete at ultimate load is obtained by enhancing the service load by some factor called as load factor for giving a desired margin of safety. Hence the method is also referred to as the load factor method or the ultimate strength method.

In the ULM, stress condition at the state of impending collapse of the structure is analysed, thus using, the non-linear stress – strain curves of concrete and steel. The safety measure in the design is obtained by the use of proper load factor. The satisfactory strength performance at ultimate loads does not guarantee satisfactory strength performance at ultimate loads does not guarantee satisfactory serviceability performance at normal service loads.

Limit state method (LSM)

Limit states are the acceptable limits for the safety and serviceability requirements of the structure before failure occurs. The design of structures by this method will thus ensure that they will not reach limit states and will not become unfit for the use for which they are intended. It is worth mentioning that structures will not just fail or collapse by violating (exceeding) the limit states. Failure, therefore, implies that clearly defined limit states of structural usefulness has been exceeded.

Limit state are two types

- i) Limit state of collapse
- ii) Limit state of serviceability.

Limit states of collapse

The limit state of collapse of the structure or part of the structure could be assessed from rupture of one or more critical sections and from buckling due to elastic bending, shear, torsion and axial loads at every section shall not be less than the appropriate value at that section produced by the probable most unfavourable combination of loads on the structure using the appropriate factor of safety.

Limit state of serviceability

Limit state of serviceability deals with deflection and crocking of structures under service loads, durability under working environment during their anticipated exposure conditions during service, stability of structures as a whole, fire resistance etc.

Characteristic and design values and partial safety factor

1. Characteristic strength of materials.

The term 'characteristic strength' means that value of the strength of material below which not more than minimum acceptable percentage of test results are expected to fall. IS 456:2000 have accepted the minimum acceptable percentage as 5% for reinforced concrete structures. This means that there is 5% probability or chance of the actual strength being less than the characteristic strength.

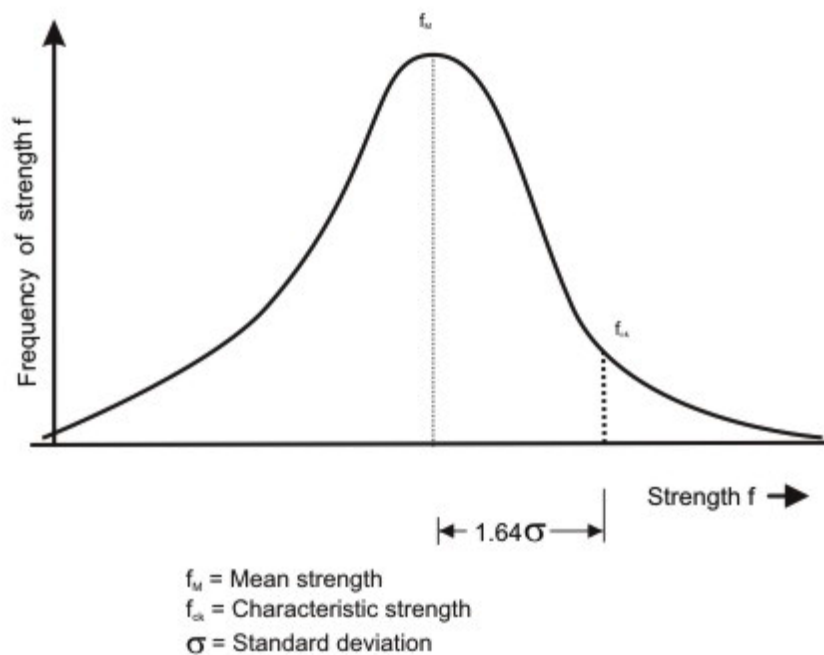

Figure 1.4: Frequency distribution curve for strength

Figure shows frequency distribution curve of strength material (concrete or steel). The value of K corresponding to 5% area of the curve is 1.65.

The design strength should be lower than the mean strength (f_m)

Characteristic strength = Mean strength – K x standard deviation or

$$f_k = f_m - K S_d$$

Where, f_k = characteristic strength of the material

f_m = mean strength

K = constant = 1.65

S_d = standard deviation for a set of test results.

The value of standard deviation (S_d) is given by

$$S_d = \sqrt{\frac{\sum \delta^2}{n-1}}$$

Where, δ =deviation of the individual test strength from the average or mean strength of n samples.

n = number of test results.

IS 456:2000 has recommended minimum value of $n=30$.

Characteristic strength of concrete

Characteristic strength of concrete is denoted by f_{ck} (N/mm^2) and its value is different for different grades of concrete e.g. M 15, M25 etc. In the symbol 'M' used for designation of concrete mix, refers to the mix and the number refers to the specified characteristic compressive strength of 150 mm size cube at 28 days expressed in N/mm^2

Characteristic strength of steel

Until the relevant Indian Standard specification for reinforcing steel are modified to include the concept of characteristic strength, the characteristic value shall be assumed as the minimum yield stress or 0.2% proof stress specified in the relevant Indian Standard specification. The characteristic strength of steel designated by symbol f_y (N/mm^2)

Characteristic loads

The term 'Characteristic load' means that values of load which has a 95% probability of not being exceeded during that life of the structure.

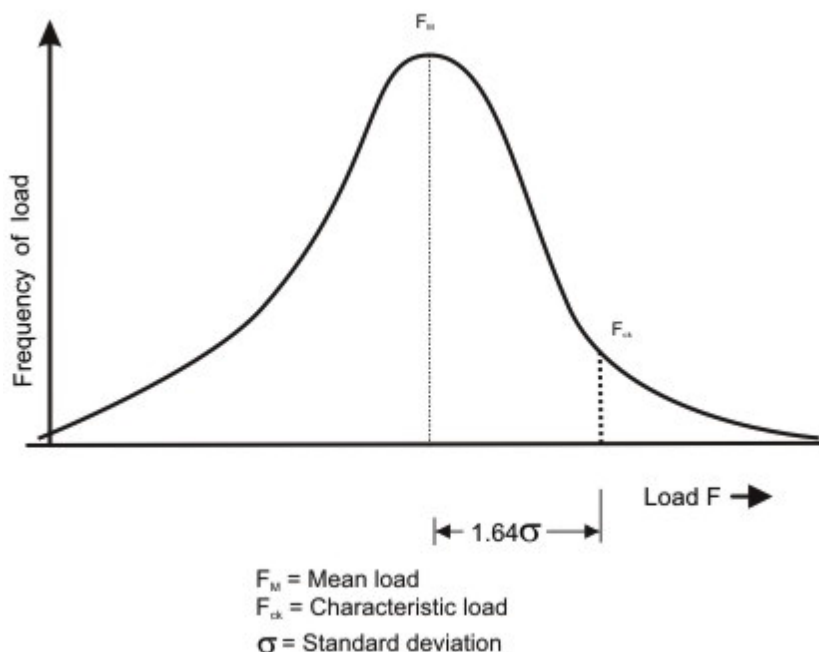

Figure 1.5: Frequency distribution curve for load

The design load should be more than average load obtained from statistic, we have

$$F_k = F_m + K S_d$$

Where, F_k = characteristic load;

F_m = mean load

K = constant = 2.65;

S_d = standard deviation for the load.

Since data are not available to express loads in statistical terms, for the purpose of this standard, dead loads given in IS 875(Part-1), imposed loads given in IS 875(Part-2), wind loads. Given in IS 875 (Part-3), snow load as given in IS 875(Part-4) and seismic forces given in IS 1893 shall be assumed as the characteristic loads.

Design strength of materials

The design strength of materials (f_d) is given by

$$f_d = \frac{f_k}{\gamma_m}$$

Where, f_k = characteristic strength of material.

γ_m = partial safety factor appropriate to the material and the limit state being considered

Design loads

The design load (F_d) is given by.

$$F_d = F_k \cdot \gamma_f$$

γ_f = partial safety factor appropriate to the nature of loading and the limit state being considered.

The design load obtained by multiplying the characteristic load by the partial safety factor for load is also known as factored load.

Partial safety factor (γ_m) for materials

When assessing the strength of a structure or structural member for the limit state of collapse, the values of partial safety factor, γ_m should be taken as 1.15 for steel.

Thus, in the limit state method, the design stress for steel reinforcement is given by $f_y / \gamma_{ms} = f_y / 1.15 = 0.87 f_y$.

According to IS 456:2000 for design purpose the compressive strength of concrete in the structure shall be assumed to be 0.67 times the characteristic strength of concrete in cube and partial safety factor $\gamma_{mc} = 1.5$ shall be applied in addition to this. Thus, the design stress in concrete is given by

$$0.67 f_{ck} / \gamma_{mc} = 0.67 f_{ck} / 1.5 = 0.446 f_{ck}$$

Partial safety factor for loads

The partial safety factors for loads, as per IS 456:2000 are given in table below

Load combination	Limit State of collapse			Limit State of Serviceability		
	DL	LL	WL/EL	DL	LL	WL/EL
DL+IL	1.5	1.5	-	1.0	1.0	-
DL+WL	1.5 or 0.9*	-	1.5	1.0	-	1.0
DL+IL+WL	1.2	1.2	1.2	1.0	0.8	0.8

(* This value is to be considered when stability against overturning or stress reversal is critical)

Limit state of collapse in flexure

The behaviour of reinforced concrete beam sections at ultimate loads has been explained in detail in previous section. The basic assumptions involved in the analysis at the ultimate limit state of flexure (Cl. 38.1 of the Code) are listed here.

- a) Plane sections normal to the beam axis remain plane after bending, i.e., in an initially straight beam, strain varies linearly over the depth of the section.
- b) The maximum compressive strain in concrete (at the outermost fibre) ϵ_{cu} shall be taken as 0.0035 in bending.
- c) The relationship between the compressive stress distribution in concrete and the strain in concrete may be assumed to be rectangle, trapezoid, parabola or any other shape which results in prediction of strength in substantial agreement with the results of test. An acceptable stress-strain curve is given below in figure 1.6. For design purposes, the compressive strength of concrete in the structure shall be assumed to be 0.67 times the characteristic strength. The partial safety factor $\gamma_m = 1.5$ shall be applied in addition to this.

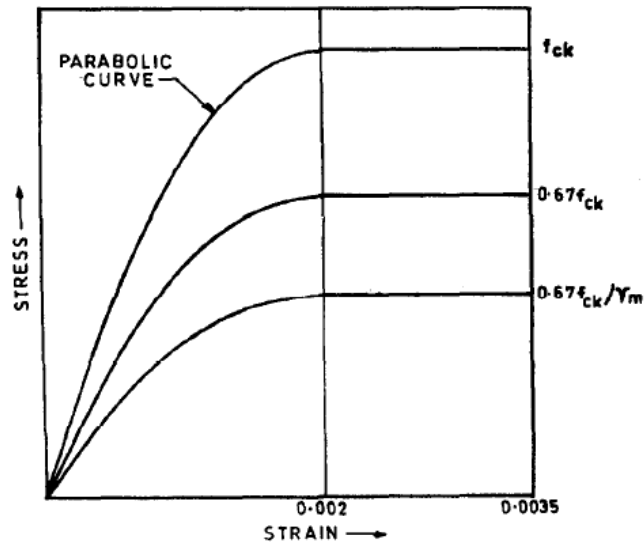

Figure 1.6 Stress-strain curve for concrete

- d) The tensile strength of the concrete is ignored.
- e) The stresses in the reinforcement are derived from representative stress-strain curve for the type of steel used. Typical curves are given in figure 1.3. For design purposes the partial safety factor γ_m equal to 1.15 shall be applied.
- f) The maximum strain in the tension reinforcement in the section at failure shall not be less

than:
$$\frac{f_y}{1.15E_s} + 0.002$$

Limiting Depth of Neutral Axis

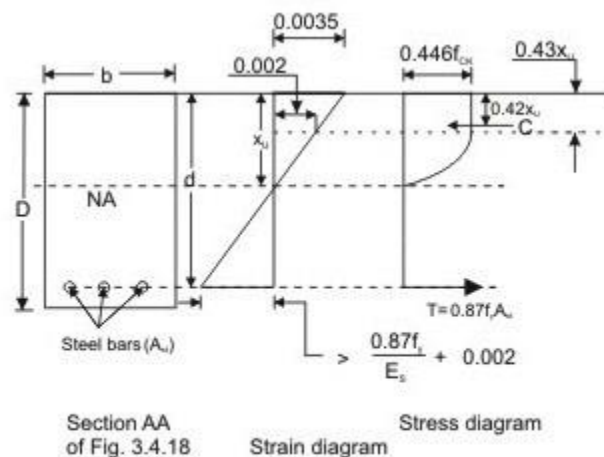

Figure: 1.7 Rectangular beam under flexure $x_u < x_{u,max}$

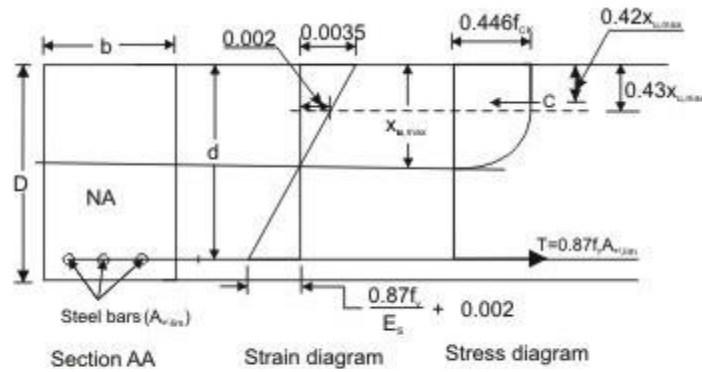

Figure 1.8 Rectangular beam under flexure $x_u = x_{u,max}$

Based on the assumption given above, an expression for the depth of the neutral axis at the ultimate limit state, x_u , can be easily obtained from the strain diagram in Fig. 1.8.

Considering similar triangles,

$$\frac{x_u}{d} = \frac{0.0035}{0.0035 + \frac{0.87f_y}{E_s} + 0.002} \quad (1)$$

According to IS 456:2000 cl no 38.1 (f), when the maximum strain in tension reinforcement is equal to $\frac{0.87f_y}{E_s} + 0.002$, then the value of neutral axis will be $x_{u,max}$.

$$\text{Therefore, } \frac{x_{u,max}}{d} = \frac{0.0035}{0.0035 + \frac{0.87f_y}{E_s} + 0.002} \quad (2)$$

The values of $x_{u,max}$ for different grades of steel, obtained by applying Eq. (2), are listed in table.

Table 1 Limiting depth of neutral axis for different grades of steel

Steel Grade	Fe 250	Fe 415	Fe 500
$x_{u,max} / d$	0.5313	0.4791	0.4791

The limiting depth of neutral axis $x_{u,max}$ corresponds to the so-called balanced section, i.e., a section that is expected to result in a 'balanced' failure at the ultimate limit state in flexure. If the neutral axis depth x_u is less than $x_{u,max}$, then the section is under-reinforced (resulting in a 'tension' failure); whereas if x_u exceeds $x_{u,max}$, it is over-reinforced (resulting in a 'compression' failure).

Analysis of Singly Reinforced Rectangular Sections

Analysis of a given reinforced concrete section at the ultimate limit state of flexure implies the determination of the *ultimate moment M_{uR} of resistance* of the section. This is easily obtained from the couple resulting from the flexural stresses (Fig 1.9).

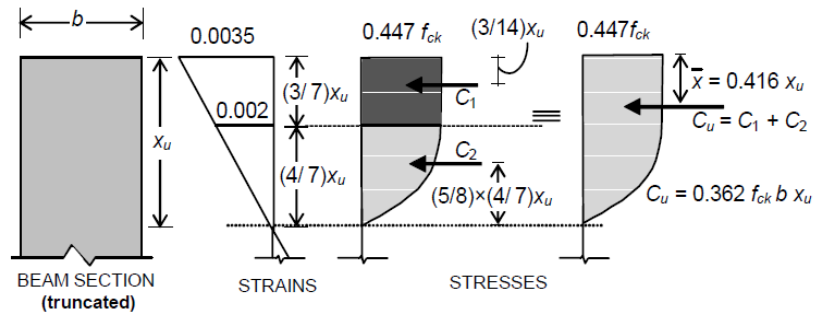

Fig. 1.9 Concrete stress-block parameters in compression

$$M_{uR} = C_u \cdot z = T_u \cdot z \quad (3)$$

where C_u and T_u are the resultant (ultimate) forces in compression and tension respectively, and z is the lever arm.

$$T_u = f_{st} \cdot A_{st} \quad (4)$$

Where $f_{st} = 0.87 f_y$ for $x_u \leq x_{u,max}$

and the line of action of T_u corresponds to the level of the centroid of the tension steel.

Concrete Stress Block in Compression

In order to determine the magnitude of C_u and its line of action, it is necessary to analyse the *concrete stress block* in compression. As ultimate failure of a reinforced concrete beam in flexure occurs by the crushing of concrete, for both under- and over-reinforced beams, the shape of the compressive stress distribution ('stress block') at failure will be, in both cases, as shown in Fig. 1.9. The value of C_u can be computed knowing that the compressive stress in concrete is uniform at $0.447 f_{ck}$ for a depth of $3x_u / 7$, and below this it varies parabolically over a depth of $4x_u / 7$ to zero at the neutral axis [Fig. 1.9].

For a rectangular section of width b ,

$$C_u = 0.447 f_{ck} b \left[\frac{3x_u}{7} + \left(\frac{2}{3} x \frac{4x_u}{7} \right) \right]$$

$$\text{Therefore, } C_u = 0.361 f_{ck} b x_u \quad (5)$$

Also, the line of action of C_u is determined by the centroid of the stress block, located at a distance \bar{x} from the concrete fibres subjected to the maximum compressive strain. Accordingly, considering moments of compressive forces C_u , C_1 and C_2 [Fig. 1.9] about the maximum compressive strain location,

$$(0.362f_{ck}bx_u) \times \bar{x} = (0.447f_{ck}bx_u) \left[\left(\frac{3}{7} \right) \left(\frac{1.5x_u}{7} \right) + \left(\frac{2}{3} \times \frac{4}{7} \right) \left(x_u - \frac{5}{8} \times \frac{4x_u}{7} \right) \right]$$

$$\text{Solving } \bar{x} = 0.416x_u \quad (6)$$

Depth of Neutral Axis

For any given section, the depth of the neutral axis should be such that $C_u = T_u$, satisfying equilibrium of forces. Equating $C_u = T_u$, with expressions for C_u and T_u given by Eq. (5) and Eq. (4) respectively.

$$x_u = \frac{0.87f_y A_{st}}{0.361f_{ck}b}, \text{ valid only if resulting } x_u \leq x_{u,\max} \quad (7)$$

Ultimate Moment of Resistance

The *ultimate moment of resistance* M_{uR} of a given beam section is obtainable from Eq. (3). The lever arm z , for the case of the singly reinforced rectangular section [Fig. 1.8, Fig. 1.9] is given by

$$z = d - 0.416x_u \quad (8)$$

Accordingly, in terms of the concrete compressive strength,

$$M_{uR} = 0.361f_{ck}bx_u(d - 0.416x_u) \text{ for all } x_u \quad (9)$$

Alternatively, in terms of the steel tensile stress,

$$M_{uR} = f_{st} A_{st}(d - 0.416x_u) \text{ for all } x_u \quad (10)$$

With $f_{st} = 0.87f_y$ for $x_u \leq x_{u,\max}$

Limiting Moment of Resistance

The *limiting moment of resistance* of a given (singly reinforced, rectangular) section, according to the Code (Cl. G-1.1), corresponds to the condition, defined by Eq. (2). From Eq. (9), it follows that:

$$M_{u,\lim} = 0.361f_{ck}bx_{u,\max}(d - 0.416x_{u,\max}) \quad (11)$$

$$M_{u,\lim} = 0.361f_{ck} \left(\frac{x_{u,\max}}{d} \right) \left(1 - \frac{0.416x_{u,\max}}{d} \right) bd^2 \quad (11a)$$

Limiting Percentage Tensile Steel

Corresponding to the limiting moment of resistance $M_{u,\text{lim}}$, there is a limiting percentage tensile steel $p_{t,\text{lim}} = 100 \times A_{st,\text{lim}} / bd$. An expression for $p_{t,\text{lim}}$ is obtainable from Eq. (7) with:

$$x_u = x_{u,\text{max}} \cdot$$

$$\frac{x_{u,\text{max}}}{d} = \frac{0.87 f_y}{0.361 f_{ck}} \times \frac{p_{t,\text{lim}}}{100}$$

$$\Rightarrow p_{t,\text{lim}} = 41.61 \left(\frac{f_{ck}}{f_y} \right) \left(\frac{x_{u,\text{max}}}{d} \right) \quad (12)$$

The values of $p_{t,\text{lim}}$ and $\frac{M_u}{bd^2}$ (in MPa units) for, different combinations of steel and concrete grades are listed in Table 2. These values correspond to the so-called ‘balanced’ section for a singly reinforced rectangular section.

Table 2 Limiting values of $p_{t,\text{lim}}$ and $\frac{M_u}{bd^2}$ for singly reinforced rectangular beam sections for various grades of steel and concrete.

(a) $p_{t,\text{lim}}$ values

	M20	M25	M30	M35	M40
Fe 250	1.769	2.211	2.653	3.095	3.537
Fe 415	0.961	1.201	1.441	1.681	1.921
Fe 500	0.759	0.949	1.138	1.328	1.518

(a) $\frac{M_{u,\text{lim}}}{bd^2}$ values (MPa)

	M20	M25	M30	M35	M40
Fe 250	2.996	3.746	4.495	5.244	5.993
Fe 415	2.777	3.472	4.166	4.860	5.555
Fe 500	2.675	3.444	4.013	4.682	5.350

Safety at Ultimate Limit State in Flexure

The bending moment expected at a beam section at the *ultimate limit state* due to the *factored loads* is called the *factored moment* M_u . For the consideration of various combinations of

loads (dead loads, live loads, wind loads, etc.), appropriate load factors should be applied to the specified ‘characteristic’ loads, and the factored moment M_u is determined by structural analysis.

The beam section will be considered to be ‘safe’, according to the Code, if its ultimate moment of resistance M_{uR} is greater than or equal to the factored moment M_u . In other words, for such a design, the *probability of failure* is acceptably low. It is also the intention of the Code to ensure that at ultimate failure in flexure, the type of failure should be a *tension (ductile) failure*. For this reason, the Code requires the designer to ensure that $x_u \leq x_{u,max}$, whereby it follows that, *for a singly reinforced rectangular section*, the tensile reinforcement percentage p_t should not exceed $p_{t,lim}$ and the ultimate moment of resistance M_{uR} should not exceed $M_{u,lim}$.

Modes of failure: Types of section

A reinforced concrete member is considered to have failed when the strain of concrete in extreme compression fibre reaches its ultimate value of 0.0035. At this stage, the actual strain in steel can have the following values:

- (a) Equal to failure strain of steel ($\frac{0.87 f_y}{E_s} + 0.002$) corresponding to balanced section.
- (b) More than failure strain, corresponding to under reinforced section.
- (c) Less than failure strain corresponding to over reinforced section.

Thus for a given section, the actual value of $\frac{x_u}{d}$ can be determined from Eq. (7). Three cases may arise.

Case-1: $\frac{x_u}{d}$ equal to the limiting value $\frac{x_{u,max}}{d}$: Balanced section.

Case-2: $\frac{x_u}{d}$ less than limiting value: under-reinforced section.

Case-3: $\frac{x_u}{d}$ more than limiting value: over-reinforced section.

In balanced section, the strain in steel and strain in concrete reach their maximum values simultaneously. The percentage of steel in this section is known as critical or limiting steel percentage. The depth of neutral axis (NA) is $x_u = x_{u,max}$.

Under-reinforced section

An under-reinforced section is the one in which steel percentage (pt) is less than critical or limiting percentage ($p_{t,lim}$). Due to this the actual NA is above the balanced NA and $x_u < x_{u,max}$.

Over-reinforced section

In the over reinforced section the steel percentage is more than limiting percentage due to which NA falls below the balanced NA and $x_u > x_{u,max}$. Because of higher percentage of steel, yield does not take place in steel and failure occurs when the strain in extreme fibres in concrete reaches its ultimate value.

Computation of M_u

M_u can be obtained by multiplying the tensile force T or the compressive force C with the lever arm. The expressions of C , lever arm and T are given in Eqs. (4) and (3) respectively. Previous section discusses that there are three possible cases depending on the location of x_u .

The corresponding expressions of M_u are given below for the three cases:

(i) When $x_u < x_{u,max}$

In this case the concrete reaches 0.0035, steel has started flowing showing ductility (Strain $> \frac{0.87 f_y}{E_s} + 0.002$). So, the computation of M_u is to be done using the tensile force of steel in this case.

Therefore, $M_u = T (\text{lever arm}) = 0.87 f_{y\ st} A_{st} (d - 0.42 x_u)$

(ii) When $x_u = x_{u,max}$

In this case steel just reaches the value of $\frac{0.87 f_y}{E_s} + 0.002$ and concrete also reaches its

maximum value. The strain of steel can further increase but the reaching of limiting strain of concrete should be taken into consideration to determine the limiting M_u as $M_{u, lim}$ here. So, we have

$$M_{u,lim} = C \text{ (lever arm)}$$

Substituting the expressions of C

$$M_{u,lim} = 0.36 \frac{x_{u,max}}{d} \left(1 - 0.42 \frac{x_{u,max}}{d} \right) f_{ck} b d^2$$

(iii) When $x_u > x_{u,max}$

In this case, concrete reaches the strain of 0.0035, tensile strain of steel is much less than $\left(\frac{0.87 f_y}{E_s} + 0.002 \right)$ and any further increase of strain of steel will mean failure of concrete,

which is to be avoided. On the other hand, when steel reaches $\frac{0.87 f_y}{E_s} + 0.002$, the strain of

concrete far exceeds 0.0035. Hence, it is not possible. Therefore, such design is avoided and the section should be redesigned.

However, in case of any existing reinforced concrete beam where $x_u > x_{u,max}$, the moment of resistance M_u for such existing beam is calculated by restricting x_u to $x_{u,max}$ only and the corresponding M_u will be as per the case when $x_u = x_{u,max}$.

Numerical Problem

Find the moment of resistance of a singly reinforced concrete beam of 200 mm width 400mm effective depth, reinforced with 3-16 mm diameter bars of Fe 415 steel. Take M20 grade of concrete.

Solution

$$A_{st} = 3x \frac{\pi}{4} (16)^2 = 603.19 \text{ mm}^2$$

$$\% p_t = 100x \frac{603.19}{200x400} = 0.754\%$$

$$\frac{x_u}{d} = 2.417 p_t \frac{f_y}{f_{ck}} = 2.417x \frac{0.754}{100} x \frac{415}{20} = 0.378$$

$$\text{Now for Fe 415 grade of steel, } \frac{x_{u,max}}{d} = 0.479$$

Hence the beam is under-reinforced.

The moment of resistance is given by

$$\begin{aligned}
 M_u &= 0.87 f_y A_{st} d \left(1 - \frac{f_y A_{st}}{f_{ck} b d} \right) \\
 &= 0.87 \times 415 \times 603.19 \times 400 \left(1 - \frac{415 \times 603.19}{20 \times 200 \times 400} \right) \\
 &= 73.48 \text{ KN-m.}
 \end{aligned}$$

Design Type of Problems

The designer has to make preliminary plan lay out including location of the beam, its span and spacing, estimate the imposed and other loads from the given functional requirement of the structure. The dead loads of the beam are estimated assuming the dimensions b and d initially. The bending moment, shear force and axial thrust are determined after estimating the different loads. In this illustrative problem, let us assume that the imposed and other loads are given. Therefore, the problem is such that the designer has to start with some initial dimensions and subsequently revise them, if needed. The following guidelines are helpful to assume the design parameters initially.

(i) Selection of breadth of the beam b

Normally, the breadth of the beam b is governed by: (i) proper housing of reinforcing bars and (ii) architectural considerations. It is desirable that the width of the beam should be less than or equal to the width of its supporting structure like column width, or width of the wall etc. Practical aspects should also be kept in mind. It has been found that most of the requirements are satisfied with b as 150, 200, 230, 250 and 300 mm. Again, width to overall depth ratio is normally kept between 0.5 and 0.67.

(ii) Selection of depths of the beam d and D

The effective depth has the major role to play in satisfying (i) the strength requirements of bending moment and shear force, and (ii) deflection of the beam. The initial effective depth of the beam, however, is assumed to satisfy the deflection requirement depending on the span and type of the reinforcement. IS 456 stipulates the basic ratios of span to effective depth of beams for span up to 10 m as (Clause 23.2.1)

Cantilever 7

Simply supported 20

Continuous 26

For spans above 10 m, the above values may be multiplied with 10/span in metres, except for cantilevers where the deflection calculations should be made. Further, these ratios are to be

multiplied with the modification factor depending on reinforcement percentage and type. Figures 4 and 5 of IS 456 give the different values of modification factors. The total depth D can be determined by adding 40 to 80 mm to the effective depth.

(iii) Selection of the amount of steel reinforcement A_{st}

The amount of steel reinforcement should provide the required tensile force T to resist the factored moment M_u of the beam. Further, it should satisfy the minimum and maximum percentages of reinforcement requirements also. The minimum reinforcement A_s is provided for creep, shrinkage, thermal and other environmental requirements irrespective of the strength requirement. The minimum reinforcement A_s to be provided in a beam depends on the f_y of steel and it follows the relation: (cl. 26.5.1.1a of IS 456)

$$\frac{A_s}{bd} = \frac{0.85}{f_y}$$

The maximum tension reinforcement should not exceed $0.04 bD$ (cl. 26.5.1.1b of IS 456), where D is the total depth.

Besides satisfying the minimum and maximum reinforcement, the amount of reinforcement of the singly reinforced beam should normally be 75 to 80% of $p_{t, lim}$. This will ensure that

strain in steel will be more than $(\frac{0.87 f_y}{E_s} + 0.002)$ as the design stress in steel will be $0.87 f_y$.

Moreover, in many cases, the depth required for deflection becomes more than the limiting depth required to resist $M_{u, lim}$. Thus, it is almost obligatory to provide more depth. Providing

more depth also helps in the amount of the steel which is less than that required for $M_{u, lim}$.

This helps to ensure ductile failure. Such beams are designated as under-reinforced beams.

(iv) Selection of diameters of bar of tension reinforcement

Reinforcement bars are available in different diameters such as 6, 8, 10, 12, 14, 16, 18, 20, 22, 25, 28, 30, 32, 36 and 40 mm. Some of these bars are less available. The selection of the diameter of bars depends on its availability, minimum stiffness to resist while persons walk over them during construction, bond requirement etc. Normally, the diameters of main tensile bars are chosen from 12, 16, 20, 22, 25 and 32 mm.

(v) Selection of grade of concrete

Besides strength and deflection, durability is a major factor to decide on the grade of concrete. Table 5 of IS 456 recommends M 20 as the minimum grade under mild environmental exposure and other grades of concrete under different environmental exposures also.

(vi) Selection of grade of steel

Normally, Fe 250, 415 and 500 are in used in reinforced concrete work. Mild steel (Fe 250) is more ductile and is preferred for structures in earthquake zones or where there are possibilities of vibration, impact, blast etc.

Failure Modes due to Shear



Figure 1.10 (a) Web shear progress along dotted lines

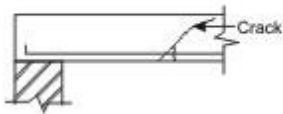

Figure 1.10 (b) Flexural tension

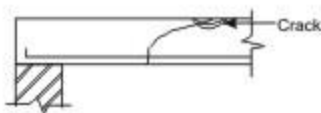

Figure 1.10 (b) Flexural compression

Bending in reinforced concrete beams is usually accompanied by shear, the exact analysis of which is very complex. However, experimental studies confirmed the following three different modes of failure due to possible combinations of shear force and bending moment at a given section:

- (i) Web shear (Fig. 1.10a)
- (ii) Flexural tension shear (Fig. 1.10b)
- (iii) Flexural compression shear (Fig. 1.10c)

Web shear causes cracks which progress along the dotted line shown in Fig. 1.10a. Steel yields in flexural tension shear as shown in Fig. 1.10b, while concrete crushes in compression due to flexural compression shear as shown in Fig. 1.10c. An in-depth presentation of the

three types of failure modes is beyond the scope here. Only the salient points needed for the routine design of beams in shear are presented here.

Shear Stress

The distribution of shear stress in reinforced concrete rectangular, *T* and *L*-beams of uniform and varying depths depends on the distribution of the normal stress. However, for the sake of simplicity the nominal shear stress τ_v is considered which is calculated as follows (IS 456, cls. 40.1 and 40.1.1):

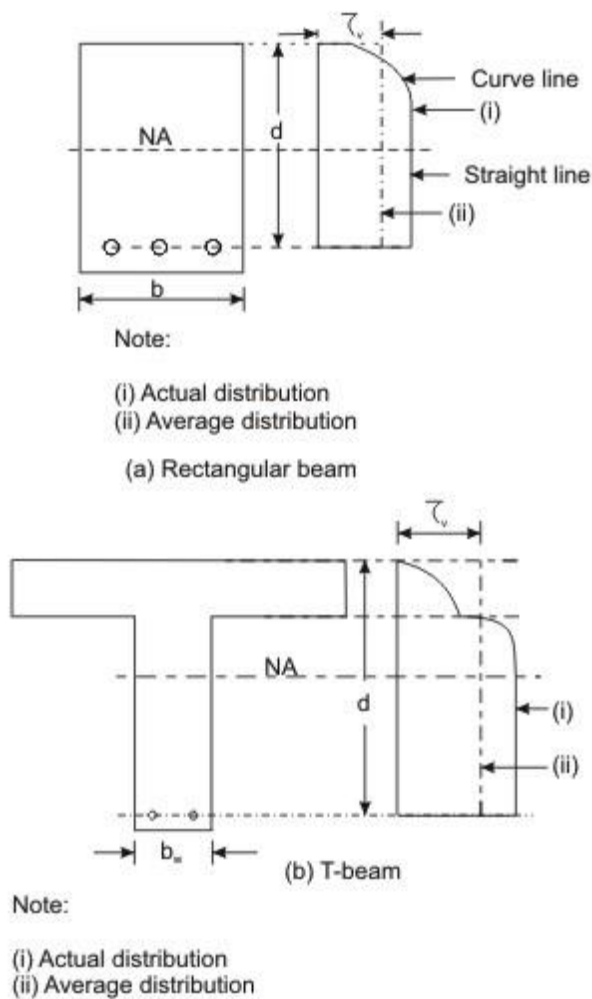

Figure 1.11: Distribution of shear stress and average shear stress

(i) In beams of uniform depth (Figs. 1.11a and b):

$$\tau_v = \frac{V_u}{bd} \quad (13)$$

where V_u = shear force due to design loads,

b = breadth of rectangular beams and breadth of the web b_w for flanged beams, and

d = effective depth.

(ii) In beams of varying depth:

$$\tau_v = \frac{V_u \pm \frac{M_u}{d} \tan \beta}{bd} \quad (14)$$

where τ_v , V_u , b or b_w and d are the same as in (i),

M_u = bending moment at the section, and

β = angle between the top and the bottom edges.

The positive sign is applicable when the bending moment M_u decreases numerically in the same direction as the effective depth increases, and the negative sign is applicable when the bending moment M_u increases numerically in the same direction as the effective depth increases.

Design Shear Strength of Reinforced Concrete

Recent laboratory experiments confirmed that reinforced concrete in beams has shear strength even without any shear reinforcement. This shear strength (τ_c) depends on the grade of concrete and the percentage of tension steel in beams. On the other hand, the shear strength of reinforced concrete with the reinforcement is restricted to some maximum value τ_{cmax} depending on the grade of concrete. These minimum and maximum shear strengths of reinforced concrete (IS 456, cls. 40.2.1 and 40.2.3, respectively) are given below:

Design shear strength without shear reinforcement (IS 456, cl. 40.2.1)

Table 19 of IS 456 stipulates the design shear strength of concrete τ_c for different grades of concrete with a wide range of percentages of positive tensile steel reinforcement. It is worth mentioning that the reinforced concrete beams must be provided with the minimum shear reinforcement as per cl. 40.3 even when τ_v is less than τ_c given in Table 3.

Table 3 Design shear strength of concrete, τ_c in N/mm^2

$100A_s / bd$	Grade of concrete				
	M 20	M 25	M 30	M 35	M40 and above
≤ 0.15	0.28	0.29	0.29	0.29	0.30
0.25	0.36	0.36	0.37	0.37	0.38
0.50	0.48	0.49	0.50	0.50	0.51
0.75	0.56	0.57	0.59	0.59	0.60

1.00	0.62	0.64	0.66	0.67	0.68
1.25	0.67	0.70	0.71	0.73	0.74
1.50	0.72	0.74	0.76	0.78	0.79
1.75	0.75	0.78	0.80	0.82	0.84
2.00	0.79	0.82	0.84	0.86	0.88
2.25	0.81	0.85	0.88	0.90	0.92
2.50	0.82	0.88	0.91	0.93	0.95
2.75	0.82	0.90	0.94	0.96	0.98
≥ 3.00	0.82	0.92	0.96	0.99	1.01

In Table 3, A_s is the area of longitudinal tension reinforcement which continues at least one effective depth beyond the section considered except at support where the full area of tension reinforcement may be used provided the detailing is as per IS 456, cls. 26.2.2 and 26.2.3.

Maximum shear stress $\tau_{c,max}$ with shear reinforcement (cls. 40.2.3, 40.5.1 and 41.3.1)

Table 20 of IS 456 stipulates the maximum shear stress of reinforced concrete in beams $\tau_{c,max}$ as given below in Table 6.2. Under no circumstances, the nominal shear stress in beams τ_v shall exceed $\tau_{c,max}$ given in Table 6.2 for different grades of concrete.

Table 4 Maximum shear stress, $\tau_{c,max}$ in N/mm^2

Grade of concrete	M 20	M 25	M 30	M 35	M 40 and above
$\tau_{c,max}$ N/mm^2	2.8	3.1	3.5	3.7	4.0

Critical Section for Shear

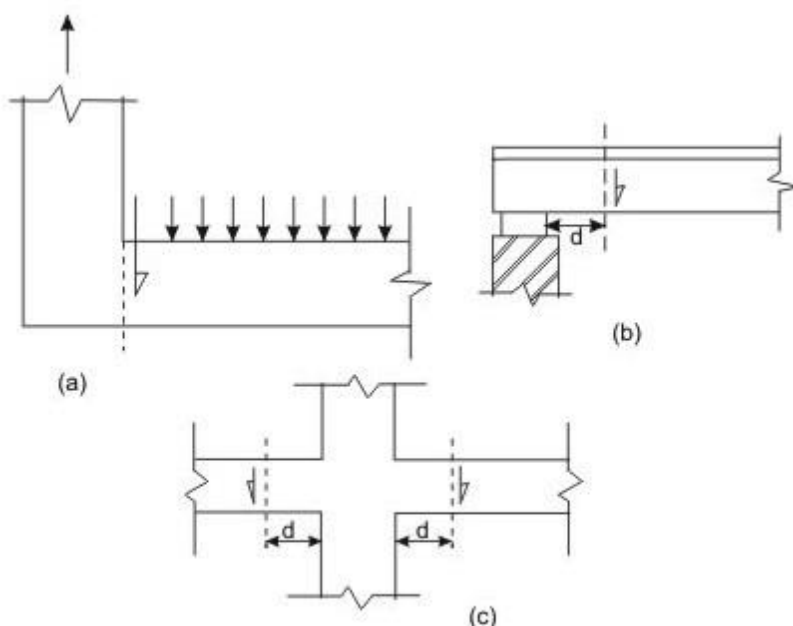

Figure 1.12 Support condition for locating factored shear force

Clauses 22.6.2 and 22.6.2.1 stipulate the critical section for shear and are as follows:

For beams generally subjected to uniformly distributed loads or where the principal load is located further than $2d$ from the face of the support, where d is the effective depth of the beam, the critical sections depend on the conditions of supports as shown in Figs. 1.12 a, b and c and are mentioned below.

(i) When the reaction in the direction of the applied shear introduces tension (Fig. 1.12a) into the end region of the member, the shear force is to be computed at the face of the support of the member at that section.

(ii) When the reaction in the direction of the applied shear introduces compression into the end region of the member (Figs. 1.12b and c), the shear force computed at a distance d from the face of the support is to be used for the design of sections located at a distance less than d from the face of the support. The enhanced shear strength of sections close to supports, however, may be considered as discussed in the following section.

Minimum Shear Reinforcement (cls. 40.3, 26.5.1.5 and 26.5.1.6 of IS 456)

Minimum shear reinforcement has to be provided even when τ_v is less than τ_c given in Table 3 as recommended in cl. 40.3 of IS 456. The amount of minimum shear reinforcement, as given in cl. 26.5.1.6, is given below.

The minimum shear reinforcement in the form of stirrups shall be provided such that:

$$\frac{A_{sv}}{bs_v} \geq \frac{0.4}{0.87f_y} \quad (15)$$

where A_{sv} = total cross-sectional area of stirrup legs effective in shear,

s_v = stirrup spacing along the length of the member,

b = breadth of the beam or breadth of the web of the web of flanged beam b_w , and

f_y = characteristic strength of the stirrup reinforcement in N/mm^2 which shall not be taken greater than 415 N/mm^2 .

The above provision is not applicable for members of minor structural importance such as lintels where the maximum shear stress calculated is less than half the permissible value.

The minimum shear reinforcement is provided for the following:

- (i) Any sudden failure of beams is prevented if concrete cover bursts and the bond to the tension steel is lost.
- (ii) Brittle shear failure is arrested which would have occurred without shear reinforcement.

- (iii) Tension failure is prevented which would have occurred due to shrinkage, thermal stresses and internal cracking in beams.
- (iv) To hold the reinforcement in place when concrete is poured.
- (v) Section becomes effective with the tie effect of the compression steel.

Further, cl. 26.5.1.5 of IS 456 stipulates that the maximum spacing of shear reinforcement measured along the axis of the member shall not be more than $0.75 d$ for vertical stirrups and d for inclined stirrups at 45° , where d is the effective depth of the section. However, the spacing shall not exceed 300 mm in any case.

Design of Shear Reinforcement (cl. 40.4 of IS 456)

When τ_v is more than τ_c given in Table 6.1, shear reinforcement shall be provided in any of the three following forms:

- (a) Vertical stirrups,
- (b) Bent-up bars along with stirrups, and
- (c) Inclined stirrups.

In the case of bent-up bars, it is to be seen that the contribution towards shear resistance of bent-up bars should not be more than fifty per cent of that of the total shear reinforcement.

The amount of shear reinforcement to be provided is determined to carry a shear force V_{us} equal to

$$V_{us} = V_u - \tau_c b d \quad (16)$$

where b is the breadth of rectangular beams or b_w in the case of flanged beams.

The strengths of shear reinforcement V_{us} for the three types of shear reinforcement are as follows:

- (a) Vertical stirrups:

$$V_{us} = \frac{0.87 f_y A_{sv} d}{s_v} \quad (17)$$

- (b) For inclined stirrups or a series of bars bent-up at different cross-sections:

$$V_{us} = \frac{0.87 f_y A_{sv} d}{s_v} (\sin \alpha + \cos \alpha) \quad (18)$$

- (c) For single bar or single group of parallel bars, all bent-up at the same cross-section:

$$V_{us} = 0.87 f_y A_{sv} d \sin \alpha \quad (19)$$

where A_{sv} = total cross-sectional area of stirrup legs or bent-up bars within a distance s_v ,

s_v = spacing of stirrups or bent-up bars along the length of the member,

τ_v = nominal shear stress,

τ_c = design shear strength of concrete,

b = breadth of the member which for the flanged beams shall be taken as the breadth of the web b_w ,

f_y = characteristic strength of the stirrup or bent-up reinforcement which shall not be taken greater than 415 N/mm^2 ,

α = angle between the inclined stirrup or bent-up bar and the axis of the member, not less than 45° , and

d = effective depth.

The following two points are to be noted:

(i) The total shear resistance shall be computed as the sum of the resistance for the various types separately where more than one type of shear reinforcement is used.

(ii) The area of stirrups shall not be less than the minimum specified in cl. 26.5.1.6.

Curtailement of Tension Reinforcement in Flexural Members (cl. 26.2.3.2 of IS 456)

Curtailement of tension reinforcement is done to provide the required reduced area of steel with the reduction of the bending moment. However, shear force increases with the reduction of bending moment. Therefore, it is necessary to satisfy any one of following three conditions while terminating the flexural reinforcement in tension zone:

(i) The shear stress τ_v at the cut-off point should not exceed two-thirds of the permitted value which includes the shear strength of the web reinforcement. Accordingly,

$$\tau_v \leq (2/3)(\tau_c + V_{us} / bd)$$

$$\text{or } V_{us} \geq (1.5\tau_v - \tau_c)bd$$

(ii) For each of the terminated bars, additional stirrup area should be provided over a distance of three-fourth of effective depth from the cut-off point. The additional stirrup area shall not be less than $0.4 b s / f_y$, where b is the breadth of rectangular beams and is replaced by b_w , the breadth of the web for flanged beams, s = spacing of additional stirrups and f_y is the characteristic strength of stirrup reinforcement in N/mm^2 . The value of s shall not exceed $d/8$

β_b), where β_b is the ratio of area of bars cut-off to the total area of bars at that section, and d is the effective depth.

(iii) For bars of diameters 36 mm and smaller, the continuing bars provide double the area required for flexure at the cut-off point. The shear stress should not exceed three-fourths that permitted. Accordingly,

$$\tau_v \leq (3/4)(\tau_c + V_{us} / bd)$$

$$\text{or } V_{us} \geq (1.33\tau_v - \tau_c)bd$$

In the above expression b is the breadth of the rectangular beams which will be b_w in the case of flanged beams.

Bond

The bond between steel and concrete is very important and essential so that they can act together without any slip in a loaded structure. With the perfect bond between them, the plane section of a beam remains plane even after bending. The length of a member required to develop the full bond is called the anchorage length. The bond is measured by bond stress. The local bond stress varies along a member with the variation of bending moment.

Thus, a tensile member has to be anchored properly by providing additional length on either side of the point of maximum tension, which is known as ‘Development length in tension’. Similarly, for compression members also, we have ‘Development length L_d in compression’.

Accordingly, IS 456, cl. 26.2 stipulates the requirements of proper anchorage of reinforcement in terms of development length L_d only employing design bond stress τ_{bd} .

Design bond stress – values

The average bond stress is still used in the working stress method and IS 456 has mentioned about it in cl. B-2.1.2. However, in the limit state method of design, the average bond stress has been designated as design bond stress τ_{bd} and the values are given in cl. 26.2.1.1. The same is given below as a ready reference.

Table 5: τ_{bd} for plain bars in tension

Grade of concrete	M 20	M 25	M 30	M 35	M 40 and above
Design Bond Stress τ_{bd} in N/mm ²	1.2	1.4	1.5	1.7	1.9

For deformed bars conforming to IS 1786, these values shall be increased by 60 per cent. For bars in compression, the values of bond stress in tension shall be increased by 25 per cent.

Development Length

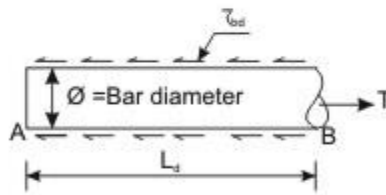

Figure 1.13 Development length of bar

Figure 1.13 shows the free body diagram of the segment AB of the bar. At B, the tensile force T trying to pull out the bar is of the value $T = (\pi \phi^2 \sigma_s / 4)$, where ϕ is the nominal diameter of the bar and σ_s is the tensile stress in bar at the section considered at design loads. It is necessary to have the resistance force to be developed by τ_{bd} for the length L_d to overcome the tensile force. The resistance force = $\pi \phi (L_d) (\tau_{bd})$. Equating the two, we get

$$\pi \phi (L_d) (\tau_{bd}) = (\pi \phi^2 \sigma_s / 4) \quad (19)$$

Equation (19), thus gives

$$L_d = \frac{\phi \sigma_s}{4 \tau_{bd}} \quad (20)$$

The above equation is given in cl. 26.2.1 of IS 456 to determine the development length of bars.

The example taken above considers round bar in tension. Similarly, other sections of the bar should have the required L_d as determined for such sections. For bars in compression, the development length is reduced by 25 per cent as the design bond stress in compression τ_{bd} is 25 per cent more than that in tension (see the last lines below Table 6.4). Following the same logic, the development length of deformed bars is reduced by 60 per cent of that needed for the plain round bars. Tables 64 to 66 of SP-16 present the development lengths of fully stressed plain and deformed bars (when $\sigma_s = 0.87 f_y$) both under tension and compression. It is to be noted that the consequence of stress concentration at the lugs of deformed bars has not been taken into consideration.

Checking of Development Lengths of Bars in Tension

The following are the stipulation of cl. 26.2.3.3 of IS 456.

(i) At least one-third of the positive moment reinforcement in simple members and one-fourth of the positive moment reinforcement in continuous members shall be extended along the same face of the member into the support, to a length equal to $L_d/3$.

(ii) Such reinforcements of (i) above shall also be anchored to develop its design stress in tension at the face of the support, when such member is part of the primary lateral load resisting system.

(iii) The diameter of the positive moment reinforcement shall be limited to a diameter such that the L_d computed for $\sigma_s = f_d$ in Eq. (20) does not exceed the following:

$$(L_d)_{when \sigma_s = f_d} \leq \frac{M_1}{V} + L_o \quad (21)$$

where M_1 = moment of resistance of the section assuming all reinforcement at the section to be stressed to f_d ,

$$f_d = 0.87 f_y,$$

V = shear force at the section due to design loads,

L_o = sum of the anchorage beyond the centre of the support and the equivalent anchorage value of any hook or mechanical anchorage at simple support. At a point of inflection, L_o is limited to the effective depth of the member or 12ϕ , whichever is greater, and

ϕ = diameter of bar.

It has been further stipulated that M_1/V in the above expression may be increased by 30 per cent when the ends of the reinforcement are confined by a compressive reaction.

Numerical problem of design of singly reinforced beam

A reinforced concrete beam is supported on two walls 250mm thick, spaced at a clear distance of 6m. The beam carries a super-imposed load of 9.8 KN/m. design the beam using M20 concrete and HYSD bars of Fe 415 grade.

Solution

The minimum depth of beam is based on limit state of serviceability requirements.

As per IS 456:2000 cl no 23.2.1 (a), for simply supported beam $l/d=20$ and for balanced section, $p_{t,lim} \approx 0.96\%$

Also for Fe 415 steel, $f_s=0.58 \times 415 = 240 \text{ N/mm}^2$

As per IS 456:2000 cl no 23.2.1(c) and fig 4 of IS 456:2000 modification factor=1.

Therefore, $l/d=20 \times 1; \Rightarrow d = l / 20 = 6000 / 20 = 300$

This is the minimum value of d. actual value of d, based on bending may be more than this.

Now from experience, assume $d=1/15=400\text{mm}$

Therefore, overall depth= effective depth+ clear cover + diameter of stirrup +0.5(diameter of main reinforcement)

$$=400+25+8+0.5\times 20=443\text{mm} \approx 450\text{mm}$$

Assume $b=250\text{mm}$

Therefore, try a trial section of dimension 250×450 .

Load Calculation

Self-weight of beam (DL)= $0.25\times 0.45\times 1\times 25=2.8125\text{ KN/m}$

Super-imposed load (LL)= 9.8 KN/m

Therefore, total load, $w=(\text{DL}+\text{LL})=(2.8125+9.8)=12.6125\text{ KN/m}$

Design load, $w_u=1.5\times w=18.9187\text{ KN/m}$

Calculation of effective span

As per IS 456:2000, cl no 22.2 (a), the effective span of a simply supported beam is lesser of the following two.

Clear span+ the effective depth of beam or slab

Or centre to centre distance between supports.

Clear span =6m

Effective depth of beam, $d=450-25-8-0.5\times 20=407\text{mm}$

Therefore, clear span + effective depth of beam= $(6+0.407)\text{m}=6.407\text{m}$

Centre to centre distance between support= $(6+0.25/2+0.25/2)\text{m}=6.25\text{m}$

Lesser of two= 6.25m

Therefore, effective span = 6.25m

Calculation of BM and SF

$$\text{Maximum BM} = \frac{w_u l^2}{8} = \frac{18.9187 \times 6.25^2}{8} = 92.376\text{ KN-m}$$

$$\text{Maximum SF} = \frac{w_u l}{2} = \frac{18.9187 \times 6.25}{2} = 59.12\text{ KN}$$

Computation of effective depth, d

For M20 grade of concrete and Fe 415 grade of steel

$$M_u = 0.138 f_{ck} b d^2$$

$$\text{Therefore, } d = \sqrt{\frac{92.376 \times 10^6}{0.138 \times 20 \times 250}} = 365.89 \text{ mm}$$

Now assumed depth was =407mm

Therefore, $r_{\text{required}} < a_{\text{assumed}}$

So, the section assumed is safe from bending moment point of view.

Since the available depth (407mm) is greater than required depth (365.89mm). So the section is under reinforced.

Calculation of steel reinforcement

The reinforcement for an under-reinforced section is given by

$$A_{st} = \frac{0.5 f_{ck}}{f_y} \left[1 - \sqrt{1 - \frac{4.6 M_u}{f_{ck} b d^2}} \right] b d = \frac{0.5 \times 20}{415} \left[1 - \sqrt{1 - \frac{4.6 \times 92.376 \times 10^6}{20 \times 250 \times 407^2}} \right] (250 \times 407)$$

$$A_{st} = 740.88 \text{ mm}^2$$

$$\% \text{pt} = 100 \frac{740.88}{250 \times 407} = 0.728\% < p_{t, \text{lim}}$$

$$\text{Therefore, using 20 mm dia, no of bars required} = \frac{740.88}{\frac{\pi}{4} (20)^2} = 2.35 \approx 3.$$

Provide 3nos 20 diameter bar.

Shear Reinforcement

As per IS 456:2000 Cl. No. 22.6.2, the critical section for shear is at a distance of 'd' from the face of the support.

So, shear force at that distance, $V_u = 59.12 - 18.9187(0.25/2 + 0.407) = 49.05 \text{ KN}$.

$$\text{Nominal shear stress, } \tau_v = \frac{V_u}{b d} = \frac{49.05 \times 10^3}{250 \times 407} = 0.482 \text{ N / mm}^2$$

$$\% p_t \text{ at support} = 100x \frac{3x \frac{\pi}{4} (20)^2}{250x407} = 0.926\%$$

As per IS 456:2000, table 19, the design shear strength of concrete, τ_c for %pt=0.926 and M20 grade of concrete, $\tau_c = 0.61 N / mm^2$

Since $\tau_v < \tau_c$, no shear reinforcement is necessary. However, minimum shear reinforcement as per cl no 26.5.1.6 of IS 456:2000 should be provided.

$$\frac{A_{sv}}{bS_v} \geq \frac{0.4}{0.87f_y} \Rightarrow S_v = \frac{2.175A_{sv}f_y}{b}$$

As per cl no 26.5.1.5 of IS 456:2000, maximum spacing of shear reinforcement least of the following

(a) 0.75d or (b) 300mm

Hence provide 2^L-8 mm diameter @ 300mm c/c throughout the length of the beam.

Check for Development length

As per cl no 26.2.1 of IS 456:2000, the development length L_d is given by

$$L_d = \frac{\phi\sigma_s}{4\tau_{bd}}$$

$\tau_{bd} = 1.2 N/mm^2$ for M20 grade of concrete.

For deformed bars conforming to Is 1786 these values shall be increased by 60%.

$$L_d = \frac{\phi\sigma_s}{(4\tau_{bd})x1.6} = \frac{20x0.87x415}{4x1.2x1.6} = 940.23 mm$$

Now as per cl no 26.2.3.3 (c) of IS 456:2000, at a simple support and at points of inflection, positive moment tension reinforcement shall be limited to a diameter such that L_d computed for f_d does not exceed

$$\frac{M_1}{V} + L_0$$

The value of $\frac{M_1}{V}$ in the above expression may be increased by 30% when the ends of the reinforcement are confined by a compressive reaction.

$$L_d \leq 1.3 \frac{M_1}{V} + L_0$$

3 bars are available at supports.

$$x_u = \frac{0.87 f_y A_{st}}{0.36 f_{ck} b} = \frac{0.87 \times 415 \times (3 \times 314.15)}{0.36 \times 20 \times 250} = 189 \text{ mm}$$

$$\begin{aligned} M_1 &= 0.87 f_y A_{st} (d - 0.416 x_u) \\ &= 0.87 \times 415 \times (3 \times 314.15) (407 - 0.416 \times 189) \\ &= 111.73 \text{ KN-m} \end{aligned}$$

$$V = 59.12 \text{ KN}$$

$L_0 =$ greatest of effective depth of member or 12ϕ

$$= 407 \text{ mm}$$

$$1.3 \frac{M_1}{V} + L_0 = 2.863 \text{ m}$$

Therefore, $L_d \leq 1.3 \frac{M_1}{V} + L_0$

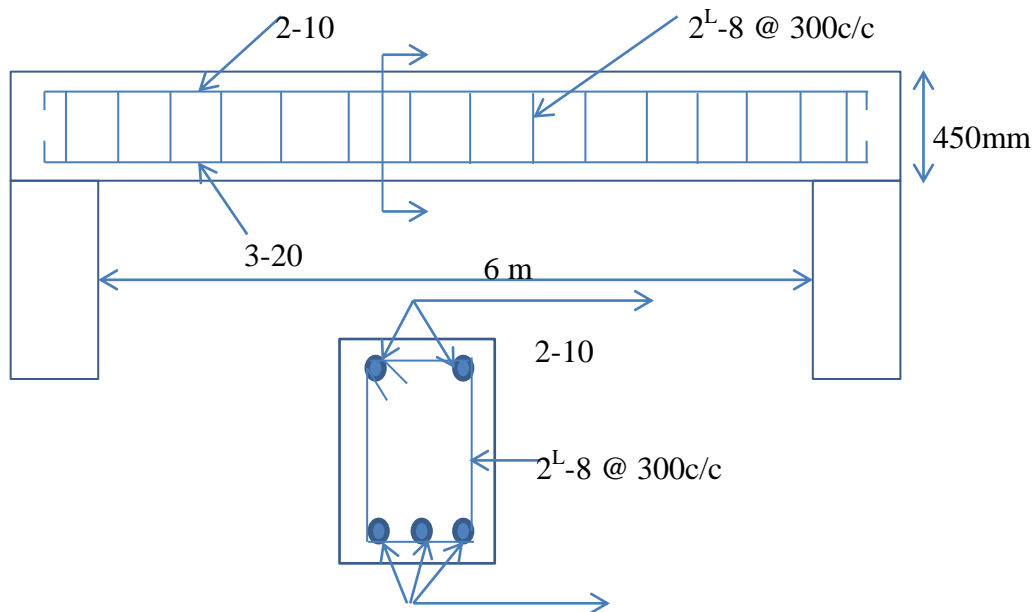

Reinforcement Detailing

Analysis and Design of Slab

One-way and Two-way Slabs

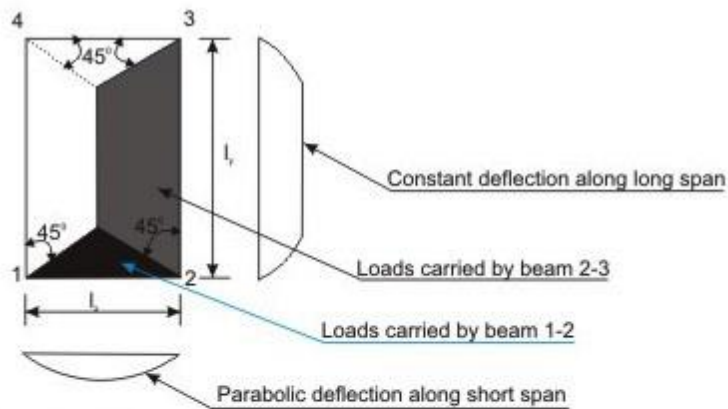
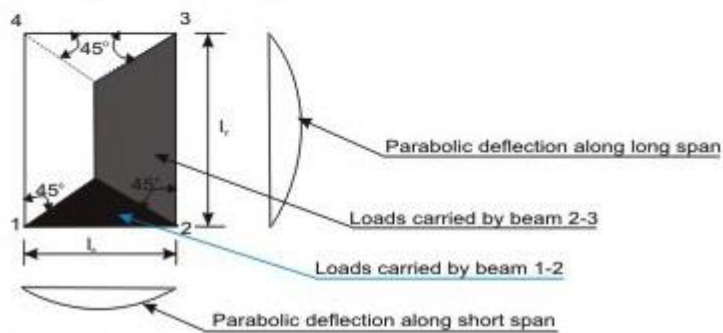
Figure 2.1(a) One-way slab ($l_y/l_x > 2$)Figure 2.1(b) Two-way slab ($l_y/l_x \leq 2$)

Figures 2.1a and b explain the share of loads on beams supporting solid slabs along four edges when vertical loads are uniformly distributed. It is evident from the figures that the share of loads on beams in two perpendicular directions depends upon the aspect ratio l_y/l_x of the slab, l_x being the shorter span. For large values of l_y/l_x , the triangular area is much less than the trapezoidal area (Fig. 2.1a). Hence, the share of loads on beams along shorter span will gradually reduce with increasing ratio of l_y/l_x . In such cases, it may be said that the loads are primarily taken by beams along longer span. The deflection profiles of the slab along both directions are also shown in the figure. The deflection profile is found to be constant along the longer span except near the edges for the slab panel of Fig. 2.1a. These slabs are designated as one-way slabs as they span in one direction (shorter one) only for a large part of the slab when $l_y/l_x > 2$.

On the other hand, for square slabs of $l_y/l_x = 1$ and rectangular slabs of l_y/l_x up to 2, the deflection profiles in the two directions are parabolic (Fig. 2.1b). Thus, they are spanning in

two directions and these slabs with l_y / l_x up to 2 are designated as two-way slabs, when supported on all edges.

It would be noted that an entirely one-way slab would need lack of support on short edges. Also, even for $l_y / l_x < 2$, absence of supports in two parallel edges will render the slab one-way. In Fig. 2.1b, the separating line at 45 degree is tentative serving purpose of design. Actually, this angle is a function of l_y / l_x .

Design of One-way Slabs

The procedure of the design of one-way slab is the same as that of beams. However, the amounts of reinforcing bars are for one metre width of the slab as to be determined from either the governing design moments (positive or negative) or from the requirement of minimum reinforcement. The different steps of the design are explained below.

Step 1: Selection of preliminary depth of slab

The depth of the slab shall be assumed from the span to effective depth ratios.

Step 2: Design loads, bending moments and shear forces

The total factored (design) loads are to be determined adding the estimated dead load of the slab, load of the floor finish, given or assumed live loads etc. after multiplying each of them with the respective partial safety factors. Thereafter, the design positive and negative bending moments and shear forces are to be determined using the respective coefficients given in Tables 12 and 13 of IS 456.

Step 3: Determination/checking of the effective and total depths of slabs

The effective depth of the slab shall be determined employing.

$$M_{u,lim} = R_{,lim} b d^2$$

The total depth of the slab shall then be determined adding appropriate nominal cover (Table 16 and 16A of cl.26.4 of IS 456) and half of the diameter of the larger bar if the bars are of different sizes. Normally, the computed depth of the slab comes out to be much less than the assumed depth in Step 1. However, final selection of the depth shall be done after checking the depth for shear force.

Step 4: Depth of the slab for shear force

Theoretically, the depth of the slab can be checked for shear force if the design shear strength of concrete is known. Since this depends upon the percentage of tensile reinforcement, the design

shear strength shall be assumed considering the lowest percentage of steel. The value of τ_c shall be modified after knowing the multiplying factor k from the depth tentatively selected for the slab in Step 3. If necessary, the depth of the slab shall be modified.

Step 5: Determination of areas of steel

Area of steel reinforcement along the direction of one-way slab should be determined employing the following Eq.

$$M_u = 0.87 f_{y\ st} A_{st} d \{1 - (A_{st})(f_y)/(f_{ck})(bd)\}$$

The above equation is applicable as the slab in most of the cases is under-reinforced due to the selection of depth larger than the computed value in Step 3. The area of steel so determined should be checked whether it is at least the minimum area of steel as mentioned in cl.26.5.2.1 of IS 456.

Step 6: Selection of diameters and spacings of reinforcing bars (cls.26.5.2.2 and 26.3.3 of IS 456)

The diameter and spacing of bars are to be determined as per cls.26.5.2.2 and 26.3.3 of IS 456. As mentioned in Step 5, this step may be avoided when using the tables and charts of SP-16.

Design the one-way continuous slab of Fig.8.18.6 subjected to uniformly distributed imposed loads of 5 kN/m^2 using M 20 and Fe 415. The load of floor finish is 1 kN/m^2 . The span dimensions shown in the figure are effective spans. The width of beams at the support = 300 mm.

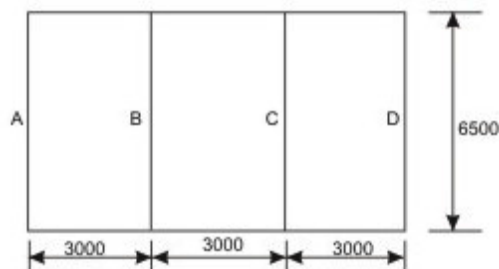

Step 1: Selection of preliminary depth of slab

The basic value of span to effective depth ratio for the slab having simple support at the end and continuous at the intermediate is $(20+26)/2 = 23$ (cl.23.2.1 of IS 456).

Modification factor with assumed $p = 0.5$ and $f_s = 240 \text{ N/mm}^2$ is obtained as 1.18 from Fig.4 of IS 456.

Therefore, the minimum effective depth $= 3000/23(1.18) = 110.54 \text{ mm}$. Let us take the effective depth $d = 115 \text{ mm}$ and with 25 mm cover, the total depth $D = 140 \text{ mm}$.

Step 2: Design loads, bending moment and shear force

Dead loads of slab of 1 m width $= 0.14(25) = 3.5 \text{ kN/m}$

Dead load of floor finish $= 1.0 \text{ kN/m}$

Factored dead load $= 1.5(4.5) = 6.75 \text{ kN/m}$

Factored live load $= 1.5(5.0) = 7.50 \text{ kN/m}$

Total factored load $= 14.25 \text{ kN/m}$

Maximum moments and shear are determined from the coefficients given in Tables 12 and 13 of IS 456.

Maximum positive moment $= 14.25(3)(3)/12 = 10.6875 \text{ kNm/m}$

Maximum negative moment $= 14.25(3)(3)/10 = 12.825 \text{ kNm/m}$

Maximum shear $V_u = 14.25(3)(0.4) = 17.1 \text{ kN}$

Step 3: Determination of effective and total depths of slab

From Eq. $M_{u,lim} = R_{,lim} b d^2$ where $R_{,lim}$ is 2.76 N/mm^2 . So, $d = \{12.825(10^6)/(2.76)(1000)\}^{0.5} = 68.17 \text{ mm}$

Since, the computed depth is much less than that determined in Step 1, let us keep $D = 140 \text{ mm}$ and $d = 115 \text{ mm}$.

Step 4: Depth of slab for shear force

Table 19 of IS 456 gives $\tau_c = 0.28 \text{ N/mm}^2$ for the lowest percentage of steel in the slab. Further for the total depth of 140 mm, let us use the coefficient k of cl. 40.2.1.1 of IS 456 as 1.3 to get $\tau_c = k\tau_c = 1.3(0.28) = 0.364 \text{ N/mm}^2$.

Table 20 of IS 456 gives $\tau_{c,max} = 2.8 \text{ N/mm}^2$. For this problem $\tau_v = \frac{V_u}{bd} = \frac{17.1}{115} = 0.148 \text{ N/mm}^2$. Since, $\tau_v < \tau_c < \tau_{c,max}$, the effective depth $d = 115 \text{ mm}$ is acceptable.

Step 5: Determination of areas of steel

It is known that

$$M_u = 0.87 f_y A_{st} d \left\{ 1 - \left(\frac{A_{st}}{bd} \right) \left(\frac{f_y}{f_{ck}} \right) \right\}$$

(i) For the maximum negative bending moment

$$12825000 = 0.87(415)(A_{st})(115) \left\{ 1 - \left(\frac{A_{st}}{(1000)(115)(20)} \right) \right\}$$

$$\text{or } -5542.16 A_{st}^2 + 1711871.646 = 0$$

Solving the quadratic equation, we have the negative $A_{st} = 328.34 \text{ mm}^2$

(ii) For the maximum positive bending moment

$$10687500 = 0.87(415)(A_{st})(115) \left\{ 1 - \left(\frac{A_{st}}{(1000)(115)(20)} \right) \right\}$$

$$\text{or } -5542.16 A_{st}^2 + 1426559.705 = 0$$

Solving the quadratic equation, we have the positive $A_{st} = 270.615 \text{ mm}^2$

Distribution steel bars along longer span l_y

Distribution steel area = Minimum steel area = $0.12(1000)(140)/100 = 168 \text{ mm}^2$. Since, both positive and negative areas of steel are higher than the minimum area, we provide:

(a) For negative steel: 10 mm diameter bars @ 230 mm c/c for which $A_{st} = 341 \text{ mm}^2$ giving $p_s = 0.2965$.

(b) For positive steel: 8 mm diameter bars @ 180 mm c/c for which $A_{st} = 279 \text{ mm}^2$ giving $p_s = 0.2426$

(c) For distribution steel: Provide 8 mm diameter bars @ 250 mm c/c for which A_{st} (minimum) = 201 mm^2 .

Step 6: Selection of diameter and spacing of reinforcing bars

The diameter and spacing already selected in step 5 for main and distribution bars are checked below:

For main bars (cl. 26.3.3.b.1 of IS 456), the maximum spacing is the lesser of $3d$ and 300 mm i.e., 300 mm. For distribution bars (cl. 26.3.3.b.2 of IS 456), the maximum spacing is the lesser of $5d$ or 450 mm i.e., 450 mm. Provided spacings, therefore, satisfy the requirements.

Maximum diameter of the bars (cl. 26.5.2.2 of IS 456) shall not exceed $140/8 = 17 \text{ mm}$ is also satisfied with the bar diameters selected here.

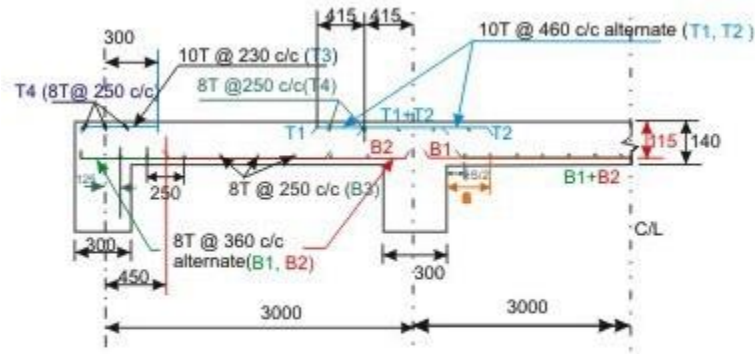

Two-way Slabs

Two-way slabs subjected mostly to uniformly distributed loads resist them primarily by bending about both the axis. However, as in the one-way slab, the depth of the two-way slabs should also be checked for the shear stresses to avoid any reinforcement for shear. Moreover, these slabs should have sufficient depth for the control deflection. Thus, strength and deflection are the requirements of design of two-way slabs.

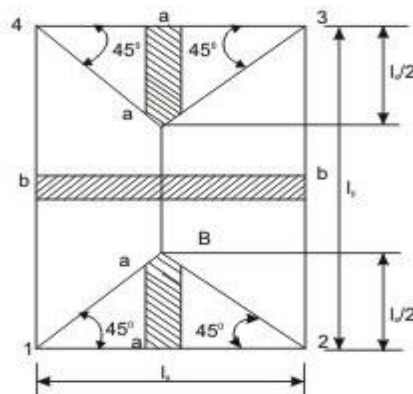

Figure 2.2 strips for shear

Computation of shear force

Shear forces are computed following the procedure stated below with reference to Fig.2.2.

The two-way slab of Fig. 2.2 is divided into two trapezoidal and two triangular zones by drawing lines from each corner at an angle of 45° . The loads of triangular segment A will be transferred to beam 1-2 and the same of trapezoidal segment B will be beam 2-3. The shear forces per unit width of the strips aa and bb are highest at the ends of strips. Moreover, the length of half the strip bb is equal to the length of the strip aa. Thus, the shear forces in both strips are equal and we can write,

$$V_u = W(l/2)$$

where W = intensity of the uniformly distributed loads.

The nominal shear stress acting on the slab is then determined from

$$\tau_v = \frac{V_u}{bd}$$

Computation of bending moments

Two-way slabs spanning in two directions at right angles and carrying uniformly distributed loads may be analysed using any acceptable theory. Pigeoud's or Westergaard's theories are the suggested elastic methods and Johansen's yield line theory is the most commonly used in the limit state of collapse method and suggested by IS 456 in the note of cl. 24.4. Alternatively, Annex D of IS 456 can be employed to determine the bending moments in the two directions for two types of slabs: (i) restrained slabs, and (ii) simply supported slabs. The two methods are explained below:

(i) Restrained slabs

Restrained slabs are those whose corners are prevented from lifting due to effects of torsional moments. These torsional moments, however, are not computed as the amounts of reinforcement are determined from the computed areas of steel due to positive bending moments depending upon the intensity of torsional moments of different corners. Thus, it is essential to determine the positive and negative bending moments in the two directions of restrained slabs depending on the various types of panels and the aspect ratio l_y/l_x .

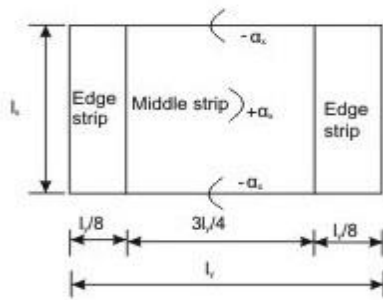

Figure 2.3 (a): For Span l_x

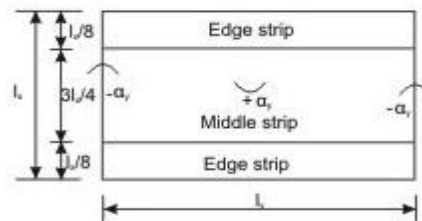

Figure 2.3 (b): For Span l_y

Restrained slabs are considered as divided into two types of strips in each direction: (i) one middle strip of width equal to three-quarters of the respective length of span in either directions, and (ii) two edge strips, each of width equal to one-eighth of the respective length of span in either directions. Figures 2.3 (a) and b present the two types of strips for spans l_x and l_y separately.

The maximum positive and negative moments per unit width in a slab are determined from

$$M_x = \alpha_x w l_x^2 \quad (1)$$

$$M_y = \alpha_y w l_y^2 \quad (2)$$

where α_x and α_y are coefficients given in Table 26 of IS 456, Annex D, cl. D-1.1. Total design load per unit area is w and lengths of shorter and longer spans are represented by l_x and l_y , respectively. The values of α_x and α_y , given in Table 26 of IS 456, are for nine types of panels having eight aspect ratios of l_y/l_x from one to two at an interval of 0.1. The above maximum bending moments are applicable only to the middle strips and no redistribution shall be made.

Tension reinforcing bars for the positive and negative maximum moments are to be provided in the respective middle strips in each direction. Figure 2.3 shows the positive and negative coefficients α_x and α_y .

The edge strips will have reinforcing bars parallel to that edge following the minimum amount as stipulated in IS 456.

(ii) Simply supported slabs

The maximum moments per unit width of simply supported slabs, not having adequate provision to resist torsion at corners and to prevent the corners from lifting, are determined from Eqs.(1) and (2), where α_x and α_y are the respective coefficients of moments as given in Table 27 of IS 456, cl. D-2. The notations M_x , M_y , w , l_x and l_y are the same as mentioned below Eqs.(1) and (2) in (i) above.

Detailing of Reinforcement

The detailings of reinforcing bars for (i) restrained slabs and (ii) simply supported slabs are discussed separately for the bars either for the maximum positive or negative bending moments or to satisfy the requirement of minimum amount of steel.

(i) Restrained slabs

The maximum positive and negative moments per unit width of the slab calculated by employing Eqs. (1) and (2) are applicable only to the respective middle strips (Fig.2.3). There shall be no redistribution of these moments. The reinforcing bars so calculated from the maximum moments are to be placed satisfying the following stipulations of IS 456.

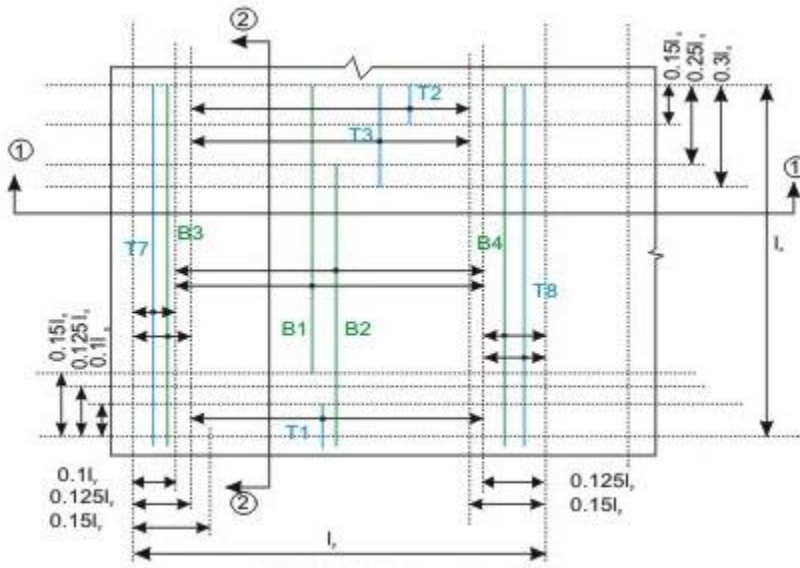

Figure 2.4 (a) Bars along l_x only

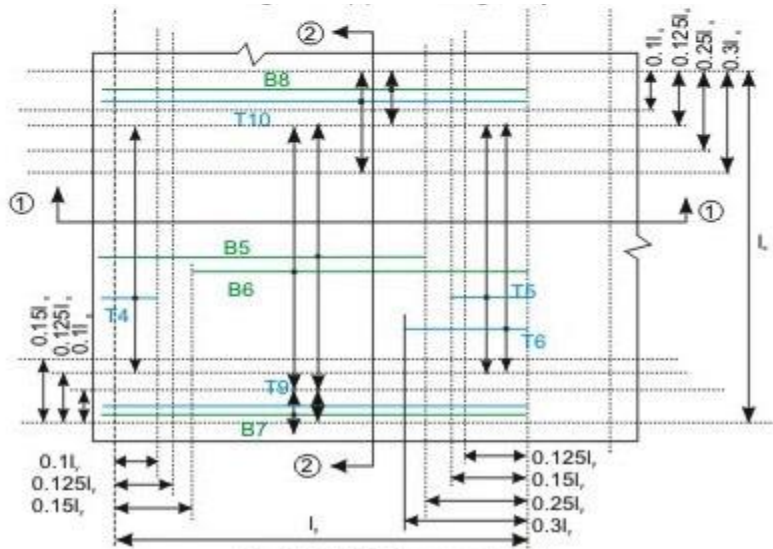

Figure 2.4 (b) Bars along l_y only

Figure 2.4 Reinforcement of two-way slab (except torsion reinforcement)

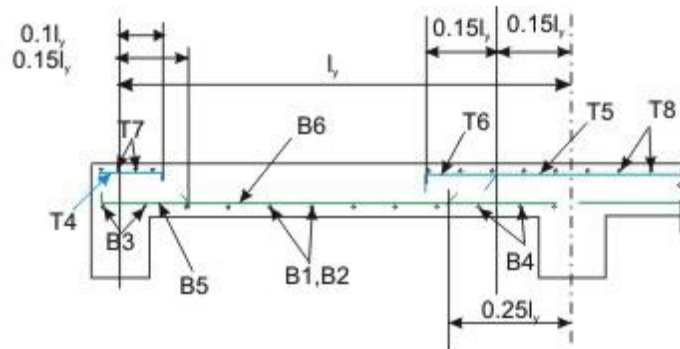

Figure 2.4 (c)

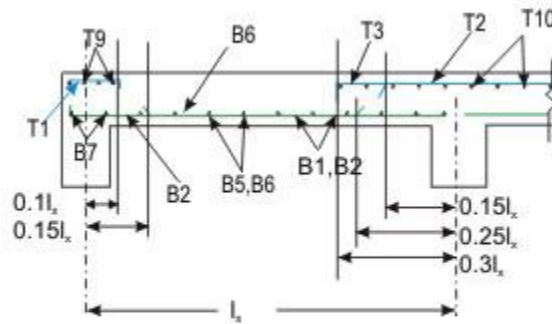

Figure 2.4 (d)

Figure 2.4 Reinforcement of two-way slab (except torsion reinforcement)

- Bottom tension reinforcement bars of mid-span in the middle strip shall extend in the lower part of the slab to within $0.25l$ of a continuous edge, or $0.15l$ of a discontinuous edge (cl. D-1.4 of IS 456). Bars marked as B1, B2, B5 and B6 in Figs.2.4 a and b are these bars.
- Top tension reinforcement bars over the continuous edges of middle strip shall extend in the upper part of the slab for a distance of $0.15l$ from the support, and at least fifty per cent of these bars shall extend a distance of $0.3l$ (cl. D-1.5 of IS 456). Bars marked as T2, T3, T5 and T6 in Figs.8.19.5 a and b are these bars.
- To resist the negative moment at a discontinuous edge depending on the degree of fixity at the edge of the slab, top tension reinforcement bars equal to fifty per cent of that provided at mid-span shall extend $0.1l$ into the span (cl. D-1.6 of IS 456). Bars marked as T1 and T4 in Figs. 2.4 a and b are these bars.
- The edge strip of each panel shall have reinforcing bars parallel to that edge satisfying the requirement of minimum reinforcement. The bottom and top bars of the edge strips are explained below.
- Bottom bars B3 and B4 (Fig. 2.4 a) are parallel to the edge along l_x for the edge strip for span l_y , satisfying the requirement of minimum amount of steel (cl. D-1.7 of IS 456).

- Bottom bars B7 and B8 (Fig. 2.4 b) are parallel to the edge along l_y for the edge strip for span l_x , satisfying the requirement of minimum amount of steel (cl. D-1.7 of IS 456).
- Top bars T7 and T8 (Fig. 2.4a) are parallel to the edge along l_x for the edge strip for span l_y , satisfying the requirement of minimum amount of steel (cl. D-1.7 of IS 456).
- Top bars T9 and T10 (Fig. 2.4 b) are parallel to the edge along l_y for the edge strip for span l_x , satisfying the requirement of minimum amount of steel (cl. D-1.7 of IS 456).

(ii) Simply supported slabs

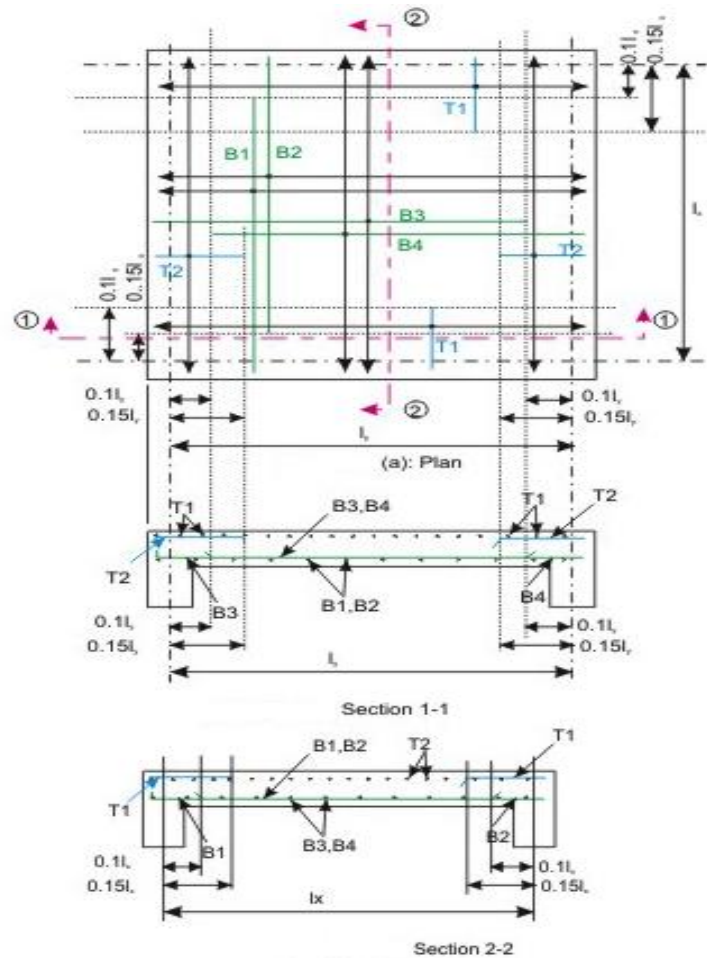

Figure 2.5 Simply supported two-way slab, corners not held down

Figures 2.5 a, b and c present the detailing of reinforcing bars of simply supported slabs not having adequate provision to resist torsion at corners and to prevent corners from lifting. Clause D-2.1 stipulates that fifty per cent of the tension reinforcement provided at mid-span should extend to the supports. The remaining fifty per cent should extend to within $0.1l_x$ or $0.1l_y$ of the support, as appropriate.

Numerical Problem

Design a R.C. slab for a room measuring 5mx6m size. The slab is simply supported on all the four edges, with corners held down and carries a super-imposed load of 3 KN/m^2 inclusive of floor finish etc. Use M20 grade of concrete and Fe 415 grade of steel.

Solution

Computation of loading and bending moment

From deflection point of view $l/d=20$ for simply supported slab. Let us assume $p_t = 0.2\%$ for an under-reinforced section. Hence from figure 4 of IS 456:2000, we get modification factor =1.68.

Hence $l/d=20 \times 1.68 = 33.6$

and $d = l/33.6 = 5000/33.6 = 148.8 \text{ mm}$

Providing 20 mm nominal cover and 8 mm bar

$D=148.8+20+8=172.8 \text{ mm}$

Hence assume an overall depth of 180 mm for the purpose of computing dead load

(i) Self weight of slab per $\text{m}^2 = 0.18 \times 1 \times 1 \times 25 = 4.5 \text{ KN/m}^2$

(ii) Super-imposed load @ $3 \text{ KN/m}^2 = 3 \text{ KN/m}^2$

Total load $w = 7.5 \text{ KN/m}^2$

Hence $w_u = 1.5 \times 7.5 = 11.25 \text{ KN/m}^2$

Taking an effective depth of 150 mm.

Effective $l_y = 6 + 0.15 = 6.15 \text{ m}$

Effective $l_x = 5 + 0.15 = 5.15 \text{ m}$

Therefore $\frac{l_y}{l_x} = \frac{6.15}{5.15} = 1.2 < 2$

From table 27 of IS 456:2000 $\alpha_x = 0.072$ and $\alpha_y = 0.056$

$M_{ux} = \alpha_x w_u l_x^2 = 0.072 \times 11.25 \times 5.15^2 = 21.483 \text{ KN-m}$

$M_{uy} = \alpha_y w_u l_x^2 = 0.056 \times 11.25 \times 5.15^2 = 16.709 \text{ KN-m}$

For short span, width of middle strip = $\frac{3}{4} l_y = \frac{3}{4} \times 6.15 = 4.61 \text{ m}$

Width of edge strip = $0.5 \times (6.15 - 4.61) = 0.77 \text{ m}$

For long span, width of middle strip = $\frac{3}{4} l_x = \frac{3}{4} \times 5.15 = 3.87 \text{ m}$

Width of edge strip = $0.5 \times (5.15 - 3.87) = 0.64 \text{ m}$

Computation of effective depth and total depth

$$d = \sqrt{\frac{M_{ux}}{R_u b}} = \sqrt{\frac{21.483 \times 10^6}{2.761 \times 10^3}} = 88.2 \text{ mm}$$

However, from the requirement of deflection keep $D = 180 \text{ mm}$.

Therefore, $d = 180 - 20 - 4 = 156 \text{ mm}$ and that for long span $d = 156 - 8 = 148 \text{ mm}$

Computation of steel reinforcement for short span

$$A_{stx} = 0.5 \frac{f_{ck}}{f_y} \left[1 - \sqrt{1 - \frac{4.6 M_{ux}}{f_{ck} b d^2}} \right] b d = 403.2 \text{ mm}^2$$

$$\text{Spacing of 8 mm bar } S_x = \frac{1000 \times 50.3}{403.2} = 124.7 \text{ mm}$$

However, use 8 mm bars @ 120 mm c/c for the middle strip of width 4.61m.

Edge strip of length = 0.77m

$$\text{The reinforcement in the edge strip} = \frac{0.12 \times 180 \times 1000}{100} = 216 \text{ mm}^2$$

Provide spacing 8 mm 225 c/c.

Computation of steel reinforcement for long span

$$A_{sty} = 327.9 \text{ mm}^2$$

$$\text{Spacing of 8 mm bar } S_y = 153.4 \text{ mm}$$

Provide 8 mm bars @ 150 mm c/c for the middle strip of width 3.87m.

$$\text{For edge strip of width} = 0.64 \text{ m, } A_{st} = 216 \text{ mm}^2$$

Hence provide spacing 8 mm @ 225 c/c.

Torsional reinforcement at corners

$$\text{Size of torsion mesh} = \frac{l_x}{5} = \frac{5.15}{5} = 1.03 \text{ m from the centre of support or } 1.03 + 0.08 = 1.10$$

from the edge of the slab.

$$\text{Area of torsional reinforcement} = \frac{3}{4} A_{stx} = \frac{3}{4} \times 403.2 = 302.4 \text{ mm}^2$$

Required spacing 8 mm @ 166 mm

Provide spacing 8 mm @ 150 c/c.

Doubly Reinforced Beam

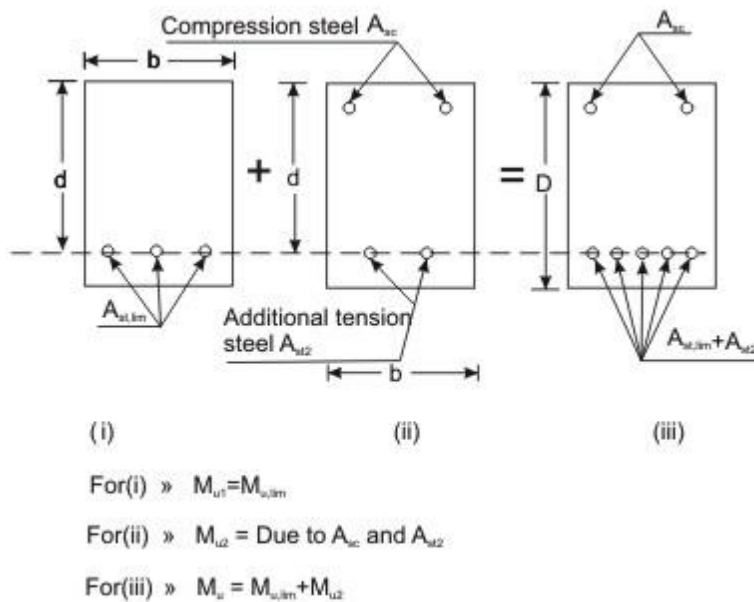

Figure 2.6 Doubly reinforced beam

Concrete has very good compressive strength and almost negligible tensile strength. Hence, steel reinforcement is used on the tensile side of concrete. Thus, singly reinforced beams reinforced on the tensile face are good both in compression and tension. However, these beams have their respective limiting moments of resistance with specified width, depth and grades of concrete and steel. The amount of steel reinforcement needed is known as $A_{st,lim}$. Problem will arise, therefore, if such a section is subjected to bending moment greater than its limiting moment of resistance as a singly reinforced section.

There are two ways to solve the problem. First, we may increase the depth of the beam, which may not be feasible in many situations. In those cases, it is possible to increase both the compressive and tensile forces of the beam by providing steel reinforcement in compression face and additional reinforcement in tension face of the beam without increasing the depth (Fig. 2.6). The total compressive force of such beams comprises (i) force due to concrete in compression and (ii) force due to steel in compression. The tensile force also has two components: (i) the first provided by $A_{st,lim}$, which is equal to the compressive force of concrete in compression. The second part is due to the additional steel in tension - its force will be equal to the compressive force of steel in compression. Such reinforced concrete

beams having steel reinforcement both on tensile and compressive faces are known as doubly reinforced beams.

Doubly reinforced beams, therefore, have moment of resistance more than the singly reinforced beams of the same depth for particular grades of steel and concrete. In many practical situations, architectural or functional requirements may restrict the overall depth of the beams. However, other than in doubly reinforced beams compression steel reinforcement is provided when:

- (i) Some sections of a continuous beam with moving loads undergo change of sign of the bending moment which makes compression zone as tension zone or vice versa.
- (ii) The ductility requirement has to be followed.
- (iii) The reduction of long term deflection is needed.

Basic Principle

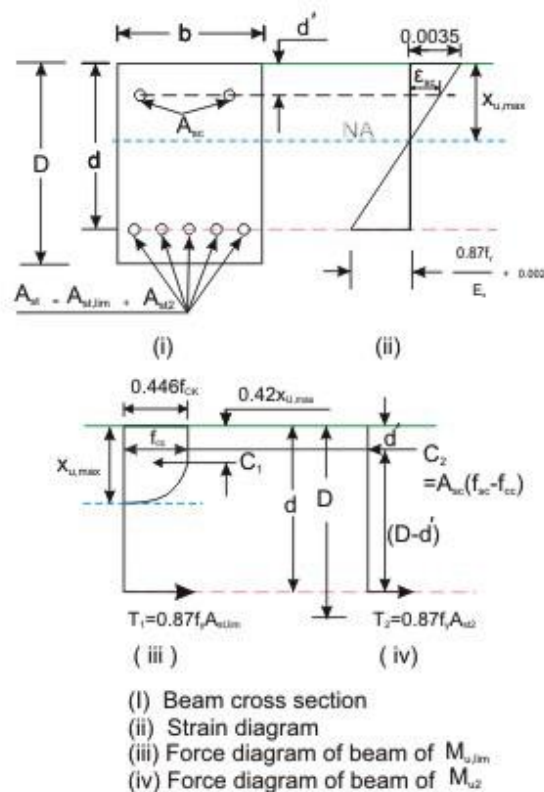

Figure 2.7 Stress, strain and force diagrams of doubly reinforced beam

The moment of resistance M_u of the doubly reinforced beam consists of (i) $M_{u,lim}$ of singly reinforced beam and (ii) M_{u2} because of equal and opposite compression and tension forces (C_2 and T_2) due to additional steel reinforcement on compression and tension faces of the beam (Figs. 2.6 and 7). Thus, the moment of resistance M_u of a doubly reinforced beam is

$$M_u = M_{u,lim} + M_{u2} \quad (3)$$

$$M_{u,lim} = 0.36 \frac{x_{u,max}}{d} \left(1 - 0.42 \frac{x_{u,max}}{d} \right) f_{ck} b d^2 \quad (4)$$

Also, $M_{u,lim}$ can be written

$$M_{u,lim} = 0.87 A_{st,lim} f_y (d - 0.416 x_{u,max}) \quad (5)$$

The additional moment M_{u2} can be expressed in two ways (Fig. 2.7): considering (i) the compressive force C_2 due to compression steel and (ii) the tensile force T_2 due to additional steel on tension face. In both the equations, the lever arm is $(d - d')$. Thus, we have

$$M_u = A_{sc} (f_{sc} - f_{cc}) (d - d') \quad (6)$$

$$M_u = A_{st} (0.87 f_y) (d - d') \quad (7)$$

where A_{sc} = area of compression steel reinforcement

f_{sc} = stress in compression steel reinforcement

f_{cc} = compressive stress in concrete at the level of centroid of compression steel reinforcement

A_{st} = area of additional steel reinforcement

Since the additional compressive force C_2 is equal to the additional tensile force T_2 , we have

$$A_{sc} (f_{sc} - f_{cc}) = A_{st} (0.87 f_y) \quad (8)$$

Any two of the three equations (Eqs. 6 - 8) can be employed to determine A_{sc} and A_{st} .

The total tensile reinforcement A_{st} is then obtained from:

$$A_{st} = A_{st1} + A_{st2} \quad (9)$$

$$A_{st1} = p_{t,lim} \frac{bd}{100} = \frac{M_{u,lim}}{0.87 f_y (d - 0.42 x_{u,max})} \quad (10)$$

Determination of f_{sc} and f_{cc}

It is seen that the values of f_{sc} and f_{cc} should be known before calculating A_{sc} . The following procedure may be followed to determine the value of f_{sc} and f_{cc} for the design type of problems (and not for analysing a given section). For the design problem the depth of the

neutral axis may be taken as $x_{u,max}$ as shown in Fig. 2.7. From Fig. 2.7, the strain at the level of compression steel reinforcement ϵ_{sc} may be written as

$$\epsilon_{sc} = 0.0035 \left(1 - \frac{d'}{x_{u,max}} \right) \quad (11)$$

f_{sc} for Cold worked bars Fe 415 and Fe 500

Table 2.1 Values of f_{sc} and ϵ_{sc}

Stress level	Fe 415		Fe 500	
	Strain ϵ_{sc}	Stress f_{sc} (N/mm ²)	Strain ϵ_{sc}	Stress f_{sc} (N/mm ²)
$0.80 f_{yd}$	0.00144	288.7	0.00174	347.8
$0.85 f_{yd}$	0.00163	306.7	0.00195	369.6
$0.90 f_{yd}$	0.00192	324.8	0.00226	391.3
$0.95 f_{yd}$	0.00241	342.8	0.00277	413.0
$0.975 f_{yd}$	0.00276	351.8	0.00312	423.9
$1.0 f_{yd}$	0.00380	360.9	0.00417	434.8

Design type of problems

In the design type of problems, the given data are b , d , D , grades of concrete and steel. The designer has to determine A_{sc} and A_{st} of the beam from the given factored moment.

Step 1: To determine $M_{u,lim}$ and $A_{st,lim}$ from Eqs. 4 and 10, respectively.

Step 2: To determine M_{u2} , A_{sc} , A_{st2} and A_{st} from Eqs. 3, 5, 8 and 9, respectively.

Step 3: To select the number and diameter of bars from known values of A_{sc} and A_{st} .

Analysis type of problems

In the analysis type of problems, the data given are b , d , d' , D , f_{ck} , f_y , A_{sc} and A_{st} . It is required to determine the moment of resistance M_u of such beams.

Step 1: To check if the beam is under-reinforced or over-reinforced.

First, $x_{u,max}$ is determined assuming it has reached limiting stage using $\frac{x_{u,max}}{d}$ coefficients as given in cl. 38.1, Note of IS 456. The strain of tensile steel ε_{st} is computed from

$$\varepsilon_{st} = \frac{\varepsilon_c (d - x_{u,max})}{x_{u,max}}$$

and is checked if ε_{st} has reached the yield strain of steel:

$$\varepsilon_{st \text{ at yield}} = \frac{f_y}{1.15E} + 0.002$$

The beam is under-reinforced or over-reinforced if ε_{st} is less than or more than the yield strain.

Step 2: To determine $M_{u,lim}$ from Eq. 4 and $A_{st,lim}$ from the $p_{t,lim}$.

Step 3: To determine A_{st2} and A_{sc} from Eqs. 9 and 8, respectively.

Step 4: To determine M_{u2} and M_u from Eqs. 6 and 3, respectively.

Numerical Problem

Determine the moment of resistance of an existing beam having the following data: $b=350$ mm; $d=900$ mm; $d' =50$ mm. Tension reinforcement: 5-20mm HYSD bars (Fe 415); compression reinforcement 2-20 HYSD bars (Fe 415); grade of concrete M15.

Solution

$$A_{st} = 5x \frac{\pi}{4} (20)^2 = 1570.8 \text{ mm}^2;$$

$$A_{sc} = 2x \frac{\pi}{4} (20)^2 = 628.3 \text{ mm}^2$$

$$T = 0.87 f_y A_{st} = 0.87 \times 415 \times 1570.8 = 567120 \text{ N}$$

$$\begin{aligned} C_u &= 0.36 f_{ck} x_u b + f_{sc} A_{sc} - 0.446 f_{ck} A_{sc} \\ &= 1890 x_u + 628.3 f_{sc} - 4203 \end{aligned}$$

Let assume $x_u = 230$ mm; hence $\frac{3}{7} x_u = 98.6$ mm $> d'$

$$\varepsilon_{sc} = \frac{0.0035(x_u - d')}{x_u} = \frac{0.0035(230 - 50)}{230} = 0.00274$$

Hence from stress-strain curve, we get $f_{sc} = 351$ N/mm²

$$C_u = 1890 \times 230 + (628.3 \times 351) - 4203 = 651030 \text{ N}$$

This is much more than $T_u = 567120 \text{ N}$. Hence take $x_u = 190 \text{ mm}$.

$$\varepsilon_{sc} = \frac{0.0035(x_u - d')}{x_u} = \frac{0.0035(190 - 50)}{190} = 0.00258$$

$$\text{Hence } f_{sc} = 347 \text{ N/mm}^2$$

$$C_u = 572919 \text{ N} \approx T$$

$$\text{Therefore, } M_u = 1890 \times 190 \times (900 - 0.416 \times 190) + (628.3 \times 347 - 4203) \times (900 - 50)$$

$$476.5 \text{ KN-m}$$

Analysis and Design of T-Beam (LSM)

T-beams and L-beams

Beams having effectively *T-sections* and *L-sections* (called *T-beams* and *L-beams*) are commonly encountered in beam-supported slab floor systems [Figs. 2.8]. In such situations, a portion of the slab acts integrally with the beam and bends in the longitudinal direction of the beam. This slab portion is called the *flange* of the T- or L-beam. The beam portion below the flange is often termed the *web*, although, technically, the web is the full rectangular portion of the beam other than the overhanging parts of the flange. Indeed, in shear calculations, the web is interpreted in this manner.

When the flange is relatively wide, the flexural compressive stress is not uniform over its width. The stress varies from a maximum in the web region to progressively lower values at points farther away from the web. In order to operate within the framework of the theory of flexure, which assumes a *uniform* stress distribution across the *width* of the section, it is necessary to define a *reduced effective flange*.

The ‘effective width of flange’ may be defined as the width of a hypothetical flange that resists in-plane compressive stresses of uniform magnitude equal to the peak stress in the original wide flange, such that the value of the resultant longitudinal compressive force is the same (Fig. 2.8).

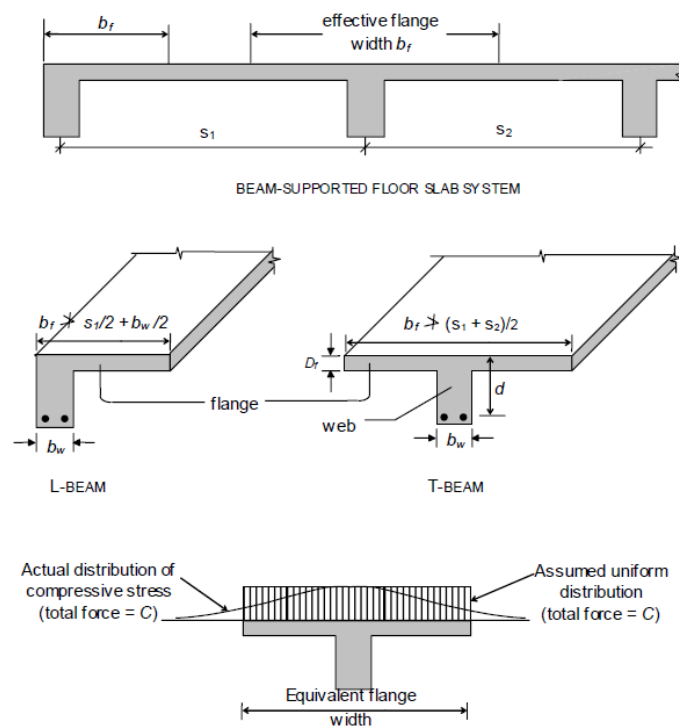

Figure 2.8 T-beams and L-beams in beam-supported floor slab systems

The effective flange width is found to increase with increased span, increased web width and increased flange thickness. It also depends on the type of loading (concentrated, distributed, etc.) and the support conditions (simply supported, continuous, etc.). Approximate formulae for estimating the ‘effective width of flange’ b_f (Cl. 23.1.2 of Code) are given as follows:

$$b_f = \begin{cases} l_0/6 + b_w + 6D_f & \text{for } T\text{-Beam} \\ l_0/12 + b_w + 3D_f & \text{for } L\text{-Beam} \end{cases} \quad (12)$$

where b_w is the breadth of the web, D_f is the thickness of the flange [Fig 2.8], and l_0 is the “distance between points of zero moments in the beam” (which may be assumed as 0.7 times the effective span in continuous beams and frames). Obviously, b_f cannot extend beyond the slab portion tributary to a beam, i.e., the actual width of slab available. Hence, the calculated b_f should be restricted to a value that does not exceed $(s_1 + s_2)/2$ in the case of T-beams, and $s_1/2 + b_w/2$ in the case of L-beams, where the spans s_1 and s_2 of the slab are as marked in Fig. 2.8.

In some situations, *isolated* T-beams and L-beams are encountered, i.e., the slab is discontinuous at the sides, as in a footbridge or a ‘stringer beam’ of a staircase. In such cases, the Code [Cl. 23.1.2(c)] recommends the use of the following formula to estimate the ‘effective width of flange’ b_f :

$$b_f = \begin{cases} \frac{l_0}{l_0/b + 4} + b_w & \text{for } \textit{isolated} T\text{-Beams} \\ \frac{0.5l_0}{l_0/b + 4} + b_w & \text{for } \textit{isolated} L\text{-Beam} \end{cases} \quad (13)$$

where b denotes the *actual* width of flange; evidently, the calculated value of b_f should not exceed b .

Analysis of Singly Reinforced Flanged Sections

The procedure for analysing flanged beams at ultimate loads depends on whether the neutral axis is located in the flange region [Fig. 2.8(a)] or in the web region [Fig. 2.8(b)].

If the neutral axis lies within the flange (i.e., $x_u \leq D_f$), then as in the analysis at service loads all the concrete on the tension side of the neutral axis is assumed ineffective, and the T-section may be analysed as a rectangular section of width b_f and effective depth d [Fig. 2.8(a)]. Accordingly, Eq. (7) and Eq. (9) are applicable with b replaced by b_f .

If the neutral axis lies in the web region (i.e., $x_u > D_f$), then the compressive stress is carried by the concrete in the flange and a portion of the web, as shown in Fig. 2.8(b). It is convenient to consider the contributions to the resultant compressive force C_u , from the *web* portion ($b_w \times x_u$) and the *flange* portion (width $b_f - b_w$) separately, and to sum up these effects. Estimating the compressive force C_{uw} in the ‘web’ and its moment contribution M_{uw} is easy, as the full stress block is operative:

$$C_{uw} = 0.361 f_{ck} b_w x_u \quad (14)$$

$$M_{uw} = C_{uw} (d - 0.416 x_u) \quad (15)$$

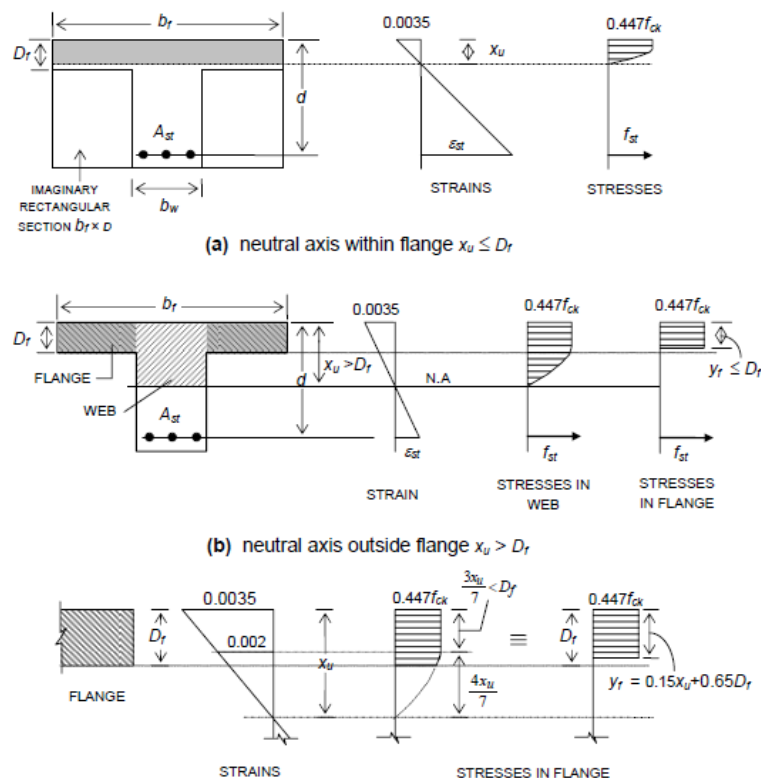

Figure 2.9 Behaviour of flanged beam section at ultimate limit state

However, estimating the compressive force C_{uf} in the flange is rendered difficult by the fact that the stress block for the flange portions may comprise a rectangular area plus a truncated parabolic area [Fig. 2.8(b)]. A general expression for the total area of the stress block operative in the flange, as well as an expression for the centroidal location of the stress block, is evidently not convenient to derive for such a case. However, when the stress block over the flange depth contains only a rectangular area (having a uniform stress $0.447 f_{ck}$), which

occurs when $\frac{3}{7}x_u \geq D_f$, an expression for C_{uf} and its moment contribution M_{uf} can easily be formulated. For the case, $1 < x_u / D_f < 7/3$, an *equivalent* rectangular stress block (of area $0.447f_{ck}y_f$) can be conceived, for convenience, with an equivalent depth $y_f \leq D_f$, as shown in Fig. 2.8(c). The expression for y_f given in the Code (Cl. G – 2.2.1) is necessarily an approximation, because it cannot satisfy the *two* conditions of ‘equivalence’, in terms of area of stress block as well as centroidal location. A general expression for y_f may be specified for any $x_u > D_f$:

$$y_f = \begin{cases} 0.15x_u + 0.65D_f & \text{for } 1 < x_u / D_f < 7/3 \\ D_f & \text{for } D_f \geq 7/3 \end{cases} \quad (16)$$

The expressions for C_{uf} and M_{uf} are accordingly obtained as:

$$C_{uf} = 0.447f_{ck}(b_f - b_w)y_f \quad \text{for } x_u > D_f \quad (17)$$

$$M_{uf} = C_{uf}(d - y_f / 2) \quad (17a)$$

The location of the neutral axis is fixed by the force equilibrium condition (with y_f expressed in terms of x_u [Eq. 17]).

$$C_{uf} + C_{st} = f_{st}A_{st} \quad (18)$$

where $f_{st} = 0.87f_y$ for $x_u \leq x_{u,max}$. Where $x_u > x_{u,max}$, the strain compatibility method has to be employed to determine x_u .

Substituting Eq. 14 and Eq. 17 in Eq. 18, and solving for x_u ,

$$x_u = \frac{f_{st}A_{st} - 0.447f_{ck}(b_f - b_w)y_f}{0.361f_{ck}b_w} \quad \text{for } x_u > D_f \quad (19)$$

The final expression for the ultimate moment of resistance M_{uR} is obtained as:

$$M_{uR} = M_{uw} + M_{uf} \quad (20)$$

$$\Rightarrow M_{uR} = 0.361f_{ck}b_w x_u (d - 0.416x_u) + 0.447f_{ck}(b_f - b_w)y_f (d - y_f / 2) \quad (21)$$

Limiting Moment of Resistance

The limiting moment of resistance $M_{u,lim}$ is obtained for the condition $x_u = x_{u,max}$, where $x_{u,max}$ takes the values of $0.531d$, $0.479d$ and $0.456d$ for Fe 250, Fe 415 and Fe 500 grades of tensile steel reinforcement. The condition $x_u / D_f \geq 7/3$ in Eq. 4.69, for the typical case of Fe 415, works out, for $x_u = x_{u,max}$, as $0.479d / D_f \geq 7/3$, i.e., $D_f \leq 205d$. The Code (Cl. G-2.2) suggests a simplified condition of $d / D_f \leq 0.2$ for all grades of steel — to represent the condition $x_u / D_f \geq 7/3$.

Eq. (21) and Eq. (16) take the following forms:

$$M_{u,lim} = 0.361 f_{ck} b_w x_{u,max} (d - 0.416 x_{u,max}) + 0.447 f_{ck} (b_f - b_w) y_f (d - y_f / 2) \text{ for } x_{u,max} > D_f \quad (22)$$

$$y_f = \begin{cases} 0.15 x_{u,max} + 0.65 D_f & \text{for } D_f / d > 0.2 \\ D_f & \text{for } D_f / d \leq 0.2 \end{cases} \quad (23)$$

The advantage of using Eq. (23) in lieu of the more exact Eq. (16) (with $x_u = x_{u,max}$) is that the estimation of y_f is made somewhat simpler. Of course, for $x_{u,max} \leq D_f$ (i.e., neutral axis within the flange),

$$M_{u,lim} = 0.361 f_{ck} b_f x_{u,max} (d - 0.416 x_{u,max}) \text{ for } x_{u,max} \leq D_f \quad (24)$$

As mentioned earlier, when it is found by *analysis* of a given T-section that $x_u > x_{u,max}$, then the strain compatibility method has to be applied. As an approximate and conservative estimate, M_{uR} may be taken as $M_{u,lim}$, given by Eq. (23) / (24). From the point of view of *design* (to be discussed in Chapter 5), $M_{u,lim}$ provides a measure of the ultimate moment capacity that can be expected from a T-section of given proportions. If the section has to be designed for a *factored moment* $M_u > M_{u,lim}$, then this calls for the provision of compression reinforcement in addition to extra tension reinforcement.

Design Procedure

In the case of a *continuous* flanged beam, the negative moment at the face of the support generally exceeds the maximum positive moment (at or near the midspan), and hence governs the proportioning of the beam cross-section. In such cases of negative moment, if the slab is

located on top of the beam (as is usually the case), the flange is under flexural tension and hence the concrete in the flange is rendered ineffective. The beam section at the support is therefore to be designed as a rectangular section for the factored negative moment. Towards the midspan of the beam, however, the beam behaves as a proper flanged beam (with the flange under flexural compression). As the width of the web b_w and the overall depth D are already fixed from design considerations at the support, all that remains to be determined is the area of reinforcing steel; the *effective width of flange* is determined as suggested by the Code .

The determination of the actual reinforcement in a flanged beam depends on the location of the neutral axis x_u , which, of course, should be limited to $x_{u,max}$. If M_u exceeds $M_{u,lim}$ for a singly reinforced flange section, the depth of the section should be suitably increased; otherwise, a doubly reinforced section is to be designed.

Neutral Axis within Flange ($x_u \leq D_f$):

This is, by far, the most common situation encountered in building design. Because of the very large compressive concrete area contributed by the flange in T-beam and L-beams of usual proportions, the neutral axis lies within the flange ($x_u \leq D_f$), whereby the section behaves like a rectangular section having width b_f and effective depth d .

A simple way of first checking $x_u \leq D_f$ is by verifying $M_u \leq (M_{uR})_{x_u=D_f}$ where $(M_{uR})_{x_u=D_f}$ is the limiting ultimate moment of resistance for the condition $x_u = D_f$ and is given by

$$(M_{uR})_{x_u=D_f} = 0.361 f_{ck} b_f D_f (d - 0.416 D_f) \quad (25)$$

It may be noted that the above equation is meaning only if $x_{u,max} > D_f$. In rare situations involving very thick flanges and relatively shallow beams, $x_{u,max}$ may be less than D_f . In such cases, $M_{u,lim}$ is obtained by substituting $x_{u,max}$ in place of D_f in Eq. (25).

Neutral Axis within Web ($x_u > D_f$):

When $M_u > (M_{uR})_{x_u=D_f}$, it follows that $x_u > D_f$. The accurate determination of x_u can be laborious. The contributions of the compressive forces C_{uw} and C_{uf} in the ‘web’ and ‘flange’ may be accounted for separately as follows:

$$M_{uR} = C_{uw}(d - 0.416x_u) + C_{uf}(d - y_f / 2) \quad (26)$$

$$C_{uw} = 0.361 f_{ck} b_w x_u \quad (27)$$

$$C_{uf} = 0.447 f_{ck} (b_f - b_w) y_f \quad (28)$$

and the equivalent flange thickness y_f is equal to or less than D_f depending on whether x_u exceeds $7D_f/3$ or not.

For $x_{u,max} \geq 7D_f/3$, the value of the ultimate moment of resistance $(M_{uR})_{x_u=7D_f/3}$ corresponding to $x_u = 7D_f/3$ and $y_f = D_f$ may be first computed. If the factored moment $M_u \geq (M_{uR})_{x_u=7D_f/3}$, it follows that $x_u > 7D_f/3$ and $y_f = D_f$. Otherwise, $D_f < x_u < 7D_f/3$ for $(M_{uR})_{x_u=D_f} < M_u < (M_{uR})_{x_u=7D_f/3}$ and

$$y_f = 0.15x_u + 0.65D_f \quad (29)$$

Inserting the appropriate value — D_f or the expression for y_f in Eq. (29), in Eq. (26), the resulting quadratic equation (in terms of the unknown x_u) can be solved to yield the correct value of x_u . Corresponding to this value of x_u , the values of C_{uw} and C_{uf} can be computed [Eq. (27), (28)] and the required A_{st} obtained by solving the force equilibrium equation.

$$T_u = 0.87 f_y A_{st} = C_{uw} + C_{uf}$$

$$\Rightarrow (A_{st})_{required} = \frac{C_{uw} + C_{uf}}{0.87 f_y} \quad (30)$$

Numerical Problem

A continuous T-beam has the cross-sectional dimensions shown in figure below. The web dimensions have been determined from the consideration of negative moment at support and shear strength requirements. The span is 10 m and the design moment at midspan under factored loads is 800 kNm. Determine the flexural reinforcement requirement at midspan. Consider Fe 415 steel. Assume that the beam is subjected to moderate exposure conditions.

Solution

Determining approximate A_{st}

Effective flange width b_f

Actual flange width provided = 1500 mm; $D_f = 100$ mm; $b_w = 300$ mm

Maximum width permitted = $(0.7 \times 10000) / 6 + 300 + (6 \times 100) = 2067$ mm > 1500 mm

Therefore, $b_f = 1500$ mm

Assuming $d = 650$ mm and a lever arm z equal to larger of $0.9d = 585$ mm

And $d - D_f/2 = 600$ mm i.e. $z = 600$ mm

$$(A_{st})_{required} = \frac{800 \times 10^6}{0.87 \times 415 \times 600} = 3693 \text{ mm}^2$$

- Providing 4 bars, $\phi_{reqd} = \sqrt{\frac{3693/4}{\pi/4}} = 34.3 \text{ mm}$, i.e., 36 mm

As 4–36 ϕ bars cannot be accommodated in one layer within the width $b_w = 300$ mm, two layers are required.

Assuming a reduced $d \approx 625$ mm, $z \approx 625 - 100/2 = 575$ mm.

$$\Rightarrow (A_{st})_{reqd} \approx 3693 \times \frac{600}{575} = 3854 \text{ mm}^2.$$

- Provide 5–32 ϕ [$A_{st} = 804 \times 5 = 4020 \text{ mm}^2$] with 3 bars in the lower layer plus 2 bars in the upper layer, with a clear vertical separation of 32 mm — as shown in Fig. 5.11(b). Assuming 8 mm stirrups and a clear 32 mm cover to stirrups,

$$\begin{aligned} \Rightarrow d &= 700 - 32 - 8 - \frac{1}{5}[(3 \times 16) + 2 \times (32 + 32 + 16)] \\ &= 700 - 40 - 41.6 = 618 \text{ mm} \end{aligned}$$

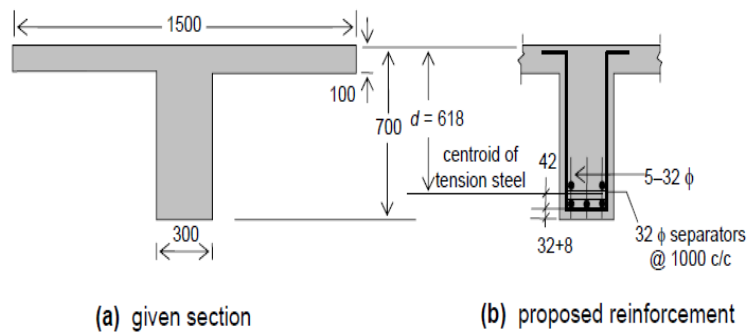

Figure: Reinforcement of T-beam of Example Problem

Determining actual A_{st}

$$x_{u,max} = 0.479 \times 618 = 296 \text{ mm}$$

As $x_{u,max} > D_f = 100 \text{ mm}$, the condition $x_u = D_f$ satisfies $x_u \leq x_{u,max}$

- Assuming M 25 concrete, $f_{ck} = 25 \text{ MPa}$

$$\begin{aligned} (M_{uR})_{x_u=D_f} &= 0.362 \times 25 \times 1500 \times 100 \times (618 - 0.416 \times 100) \\ &= 782.5 \times 10^6 \text{ Nmm} < M_u = 800 \text{ kNm} \end{aligned}$$

$$\Rightarrow x_u > D_f \text{ and } M_u = C_{uw} (d - 0.416 x_u) + C_{uf} (d - y_f/2)$$

$$\text{where } C_{uw} = 0.362 f_{ck} b_w x_u = 0.362 \times 25 \times 300 x_u = (2715 x_u) \text{ N}$$

$$\text{and } C_{uf} = 0.447 f_{ck} (b_f - b_w) y_f = 0.447 \times 25 \times (1500 - 300) y_f = (13410 y_f)$$

Considering $x_u = 7D_f/3 = 233 \text{ mm}$ ($< x_{u,max} = 296 \text{ mm}$), $y_f = D_f = 100 \text{ mm}$

$$\Rightarrow (M_{uR})_{x_u=7D_f/3} = (2715 \times 233)(618 - 0.416 \times 233) + (13410 \times 100) \times (618 - 100/2)$$

$$= 1091.3 \times 10^6 \text{ Nmm} > M_u = 800 \text{ KNm}$$

Evidently, $D_f < x_u < \frac{7}{3} D_f$, for which $y_f = 0.15x_u + 0.65D_f$

$$C_{uf} = 13410(0.15x_u + 65 \times 100) = (2011.5x_u + 871650) \text{ N}$$

$$M_u = 800 \times 10^6 = (2715x_u)(618 - 0.416x_u)$$

$$+ (2011.5x_u + 871650) \times [618 - (0.15x_u + 65)/2]$$

$$= -1280.3x_u^2 + 2790229.5x_u + 510.35 \times 10^6$$

Solving this quadratic equation,

$$x_u = \mathbf{109.3 \text{ mm}} < x_{u,max} = 296 \text{ mm}$$

$$\Rightarrow y_f = 0.15x_u + 65 = 81.4 \text{ mm}$$

$$\text{Applying } T_u = 0.87f_y A_{st} = C_{uw} + C_{uf}$$

$$(A_{st})_{required} = \frac{(2715 \times 109.3) + (13410 \times 81.4)}{0.87 \times 415} = 3845 \text{ mm}^2$$

The reinforcement (5-32Φ; $A_{st}=4020 \text{ mm}^2$, based on appropriate estimate of A_{st} [Fig.] is evidently adequate and appropriate.

Analysis and Design of Stair case (LSM)

Design of Staircase

The staircase is an important component of a building, and often the only means of access between the various floors in the building. It consists of a *flight* of steps, usually with one or more intermediate *landings* (horizontal slab platforms) provided between the floor levels. The horizontal top portion of a step (where the foot rests) is termed *tread* and the vertical projection of the step (i.e., the vertical distance between two neighbouring steps) is called *riser* [Fig. 2.10]. Values of 300 mm and 150 mm are ideally assigned to the tread and riser respectively — particularly in public buildings. However, lower values of tread (up to 250 mm) combined with higher values of riser (up to 190 mm) are resorted to in residential and factory buildings. The *width* of the stair is generally around 1.1 – 1.6m, and in any case, should normally not be less than 850 mm; large stair widths are encountered in entrances to public buildings. The horizontal projection (plan) of an inclined flight of steps, between the first and last risers, is termed *going*. A typical flight of steps consists of two landings and one going, as depicted in Fig. 2.10(a). Generally, risers in a flight should not exceed about 12 in number. The steps in the flight can be designed in a number of ways: with *waist slab*, with *tread-riser* arrangement (without waist slab) or with *isolated tread slabs* — as shown in Fig. 2.10(b), (c), (d) respectively.

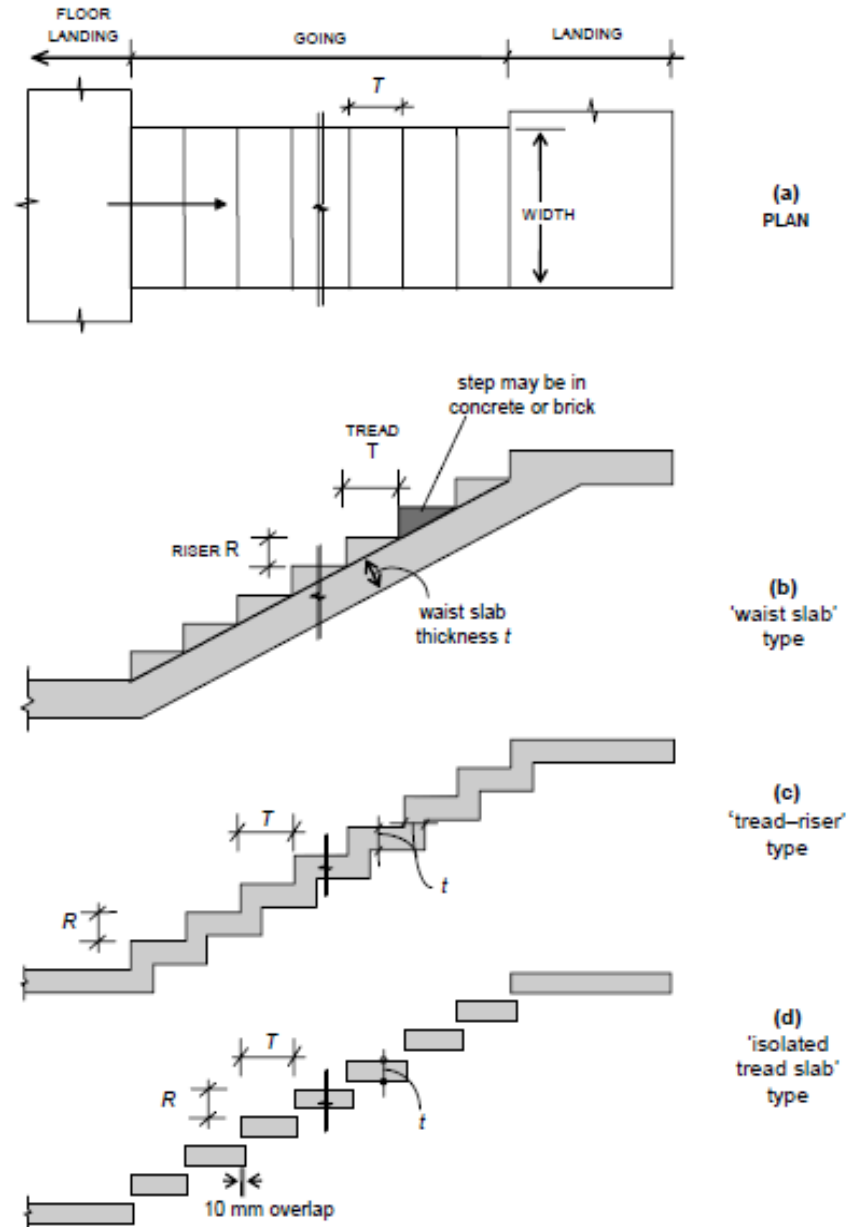

Figure 2.10 A typical flight in a staircase

TYPES OF STAIRCASES

Geometrical Configurations

A wide variety of staircases are met with in practice. Some of the more common geometrical configurations are depicted in Fig. 2.11. These include:

- straight stairs (with or without intermediate landing) [Fig. 2.11 (a)]
- quarter-turn stairs [Fig. 2.11 (b)]
- dog-legged stairs [Fig. 2.11 (c)]

- open well stairs [Fig. 2.11 (d)]
- spiral stairs [Fig. 2.11 (e)]
- helicoidal stairs [Fig. 2.11 (f)]

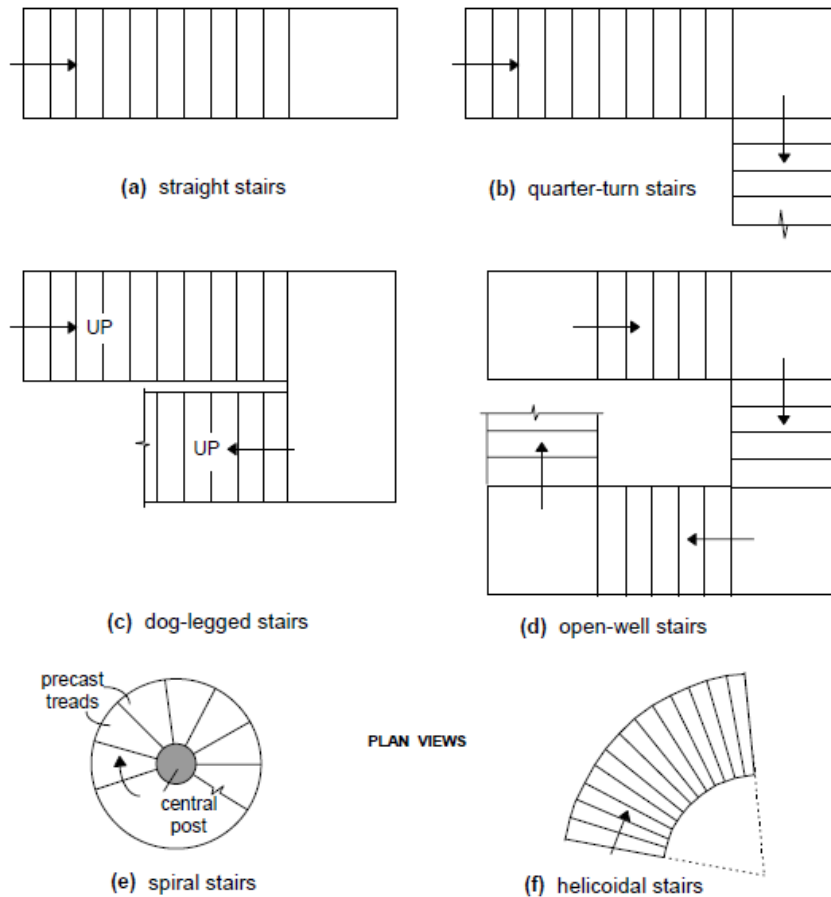

Fig. 2.11 Common geometrical configurations of stairs

Structural Classification

Structurally, staircases may be classified largely into two categories, depending on the predominant direction in which the slab component of the stair undergoes flexure:

1. Stair slab spanning transversely (stair widthwise);
2. Stair slab spanning longitudinally (along the incline).

Stair Slab Spanning Transversely

The slab component of the stair (whether comprising an isolated tread slab, a tread-riser unit or a waist slab) is supported on its side(s) or cantilevers laterally from a central support. The slab supports gravity loads by bending essentially in a *transverse vertical plane*, with the span along the *width* of the stair.

In the case of the cantilevered slabs, it is economical to provide isolated treads (without risers). However, the tread-riser type of arrangement and the waist slab type are also sometimes employed in practice, as cantilevers. The spandrel beam is subjected to torsion ('equilibrium torsion'), in addition to flexure and shear.

When the slab is supported at the two sides by means of 'stringer beams' or masonry walls, it may be designed as simply supported, but reinforcement at the top should be provided near the supports to resist the 'negative' moments that may arise on account of possible partial fixity.

Stair Slab Spanning Longitudinally

In this case, the supports to the stair slab are provided parallel to the riser at two or more locations, causing the slab to bend longitudinally between the supports. It may be noted that longitudinal bending can occur in configurations other than the straight stair configuration, such as quarter-turn stairs, dog-legged stairs, open well stairs and helicoidal stairs .

The slab arrangement may either be the conventional 'waist slab' type or the 'tread-riser' type. The slab thickness depends on the 'effective span', which should be taken as the centre-to-centre distance between the beam/wall supports, according to the Code (Cl. 33.1a, c). In certain situations, beam or wall supports may not be available parallel to the riser at the landing. Instead, the flight is supported between the landings, which span transversely, parallel to the risers. In such cases, the Code (Cl. 33.1b) specifies that the effective span for the flight (spanning longitudinally) should be taken as *the going of the stairs plus at each end either half the width of the landing or one metre, whichever is smaller.*

Numerical Problem

Design a ('waist slab' type) dog-legged staircase for an office building, given the following data:

- Height between floor = 3.2 m;
- Riser = 160 mm, tread = 270 mm;
- Width of flight = landing width = 1.25 m
- Live load = 5.0 kN/m^2
- Finishes load = 0.6 kN/m^2

Assume the stairs to be supported on 230 mm thick masonry walls at the outer edges of the landing, parallel to the risers [Fig. 12.13(a)]. Use M 20 concrete and Fe 415 steel. Assume *mild* exposure conditions.

Solution

Given: $R = 160 \text{ mm}$, $T = 270 \text{ mm} \Rightarrow +RT22$

= 314 mm Effective span = c/c distance between supports = 5.16 m [Fig below].

- Assume a waist slab thickness $\approx l/20 = 5160/20 = 258 \rightarrow 260 \text{ mm}$.

Assuming 20 mm clear cover (*mild* exposure) and 12 ϕ main bars, effective depth $d = 260 - 20 - 12/2 = 234 \text{ mm}$.

The slab thickness in the landing regions may be taken as 200 mm, as the bending moments are relatively low here.

Loads on going [fig. below] on projected plan area:

(1) self-weight of waist slab @ $25 \times 0.26 \times 314/270$	$= 7.56 \text{ kN/m}^2$
(2) self-weight of steps @ $25 \times (0.5 \times 0.16)$	$= 2.00 \text{ kN/m}^2$
(3) finishes (given)	$= 0.60 \text{ kN/m}^2$
(4) live load (given)	$= 5.00 \text{ kN/m}^2$
Total	$= 15.16 \text{ kN/m}^2$

\Rightarrow Factored load = $15.16 \times 1.5 = 22.74 \text{ kN/m}^2$

- *Loads on landing*

(1) self-weight of slab @ 25×0.20	$= 5.00 \text{ kN/m}^2$
(2) finishes	@ 0.6 kN/m^2
(3) live loads	@ 5.0 kN/m^2
Total	$= 10.60 \text{ kN/m}^2$

\Rightarrow Factored load = $10.60 \times 1.5 = 15.90 \text{ kN/m}^2$

- *Design Moment* [Fig. below]

Reaction $R = (15.90 \times 1.365) + (22.74 \times 2.43)/2 = 49.33 \text{ kN/m}$

Maximum moment at midspan:

$$\begin{aligned}
 M_u &= (49.33 \times 2.58) - (15.90 \times 1.365) \times (2.58 - 1.365/2) \\
 &\quad - (22.74) \times (2.58 - 1.365)^2 / 2 \\
 &= 69.30 \text{ kNm/m}
 \end{aligned}$$

- *Main reinforcement*

$$R = \frac{M_u}{bd^2} = 1.265 \text{ MPa}$$

Assuming $f_{ck} = 20 \text{ MPa}$, $f_y = 415 \text{ MPa}$,

$$\frac{p_t}{100} = \frac{A_{st}}{100} = 0.381 \times 10^{-2}$$

$$\Rightarrow (A_{st})_{req} = (0.381 \times 10^{-2}) \times 10^3 \times 234 = 892 \text{ mm}^2 / m$$

Required spacing of 12 ϕ bars = 127 mm

Required spacing of 16 ϕ bars = 225 mm

Provide 16 ϕ @ 220c/c

• *Distributors*

$$(A_{st})_{req} = 0.0012bt = 312 \text{ mm}^2 / m$$

spacing 10 ϕ bars = 251 mm

Provide 10 ϕ @ 250c/c as distributors.

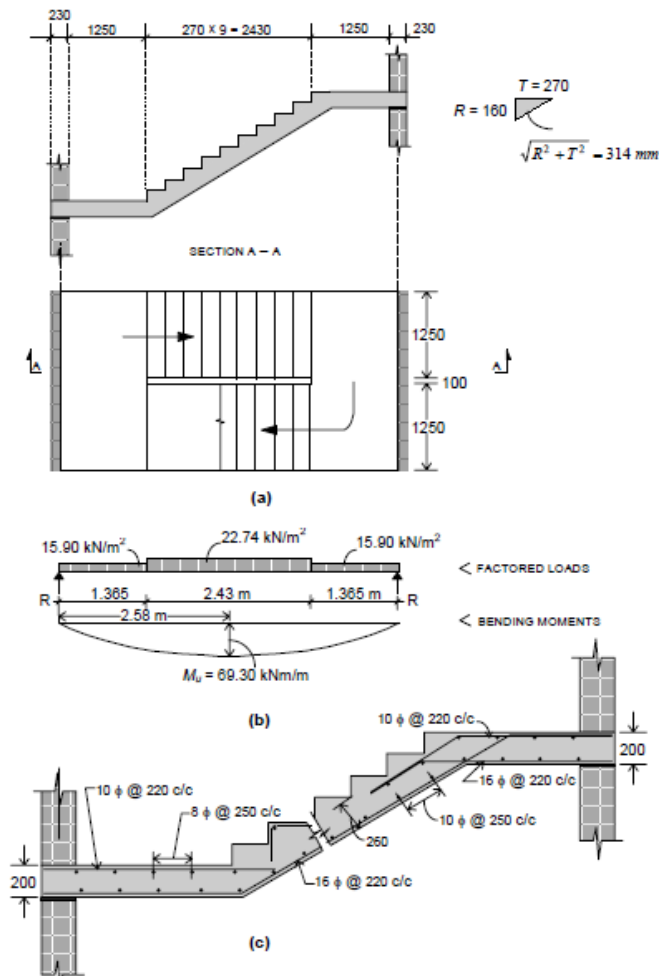

Figure for numerical problem

Design of Axially loaded columns

Introduction

Compression members are structural elements primarily subjected to axial compressive forces and hence, their design is guided by considerations of strength and buckling. Examples of compression member pedestal, column, wall and strut.

Definitions

(a) Effective length: The vertical distance between the points of inflection of the compression member in the buckled configuration in a plane is termed as effective length l_e of that compression member in that plane. The effective length is different from the unsupported length l of the member, though it depends on the unsupported length and the type of end restraints. The relation between the effective and unsupported lengths of any compression member is

$$l_e = k l \quad (1)$$

Where k is the ratio of effective to the unsupported lengths. Clause 25.2 of IS 456 stipulates the effective lengths of compression members (vide Annex E of IS 456). This parameter is needed in classifying and designing the compression members.

(b) Pedestal: Pedestal is a vertical compression member whose effective length l_e does not exceed three times of its least horizontal dimension b (cl. 26.5.3.1h, Note). The other horizontal dimension D shall not exceed four times of b .

(c) Column: Column is a vertical compression member whose unsupported length l shall not exceed sixty times of b (least lateral dimension), if restrained at the two ends. Further, its unsupported length of a cantilever column shall not exceed $100b^2/D$, where D is the larger lateral dimension which is also restricted up to four times of b (vide cl. 25.3 of IS 456).

(d) Wall: Wall is a vertical compression member whose effective height H_{we} to thickness t (least lateral dimension) shall not exceed 30 (cl. 32.2.3 of IS 456). The larger horizontal dimension i.e., the length of the wall L is more than $4t$.

Classification of Columns Based on Types of Reinforcement

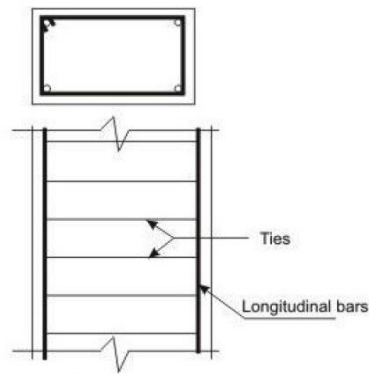

Figure 3.1(a) Tied Column

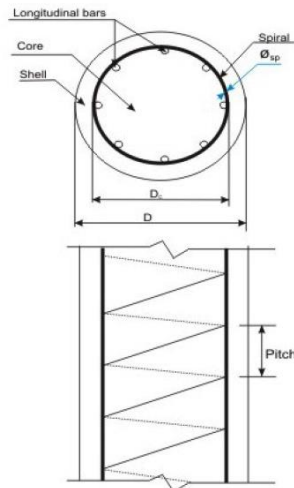

Figure 3.1(b) Column with helical reinforcement

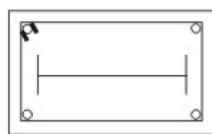

Figure 3.1(c) Composite column (steel section)

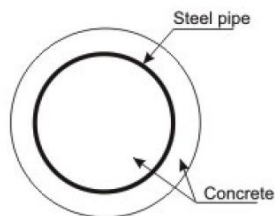

Figure 3.1(d) Composite column (steel pipe)

Figure 3.1 Tied, helically bound and composite columns

Based on the types of reinforcement, the reinforced concrete columns are classified into three groups:

- (i) Tied columns: The main longitudinal reinforcement bars are enclosed within closely spaced lateral ties (Fig.3.1a).
- (ii) Columns with helical reinforcement: The main longitudinal reinforcement bars are enclosed within closely spaced and continuously wound spiral reinforcement. Circular and octagonal columns are mostly of this type (Fig. 3.1b).
- (iii) Composite columns: The main longitudinal reinforcement of the composite columns consists of structural steel sections or pipes with or without longitudinal bars (Fig. 3.1c and d).

Out of the three types of columns, the tied columns are mostly common with different shapes of the cross-sections viz. square, rectangular etc. Helicallly bound columns are also used for circular or octagonal shapes of cross-sections.

Classification of Columns Based on Loadings

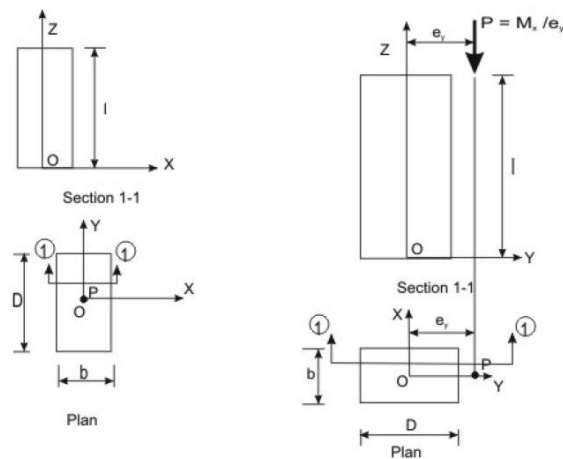

Figure 3.2(a) Axial loading (concentric) Figure 3.2(b) Axial loading with uniaxial bending

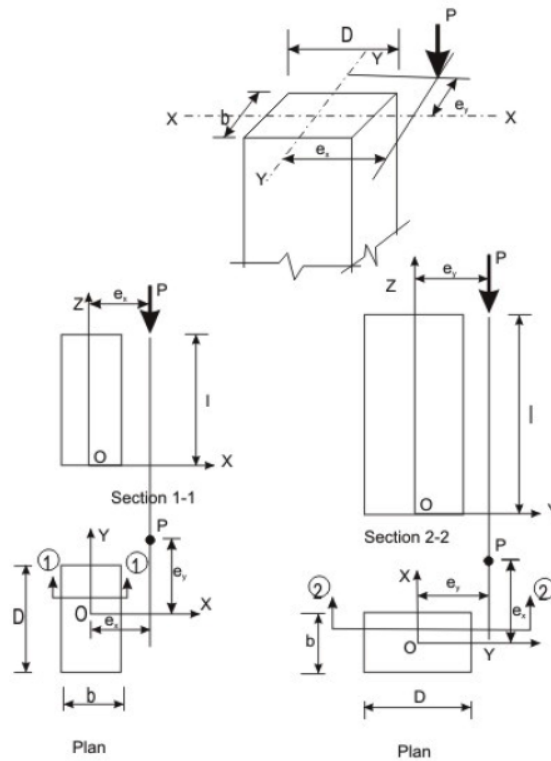

Figure 3.2(c) Axial loading with biaxial bending

Columns are classified into the three following types based on the loadings:

- (i) Columns subjected to axial loads only (concentric), as shown in Fig. 3.2a.
- (ii) Columns subjected to combined axial load and uniaxial bending, as shown in Fig. 3.2b.
- (iii) Columns subjected to combined axial load and bi-axial bending, as shown in Fig. 3.2c.

Classification of Columns Based on Slenderness Ratios

Columns are classified into the following two types based on the slenderness ratios:

- (i) Short columns
- (ii) Slender or long columns

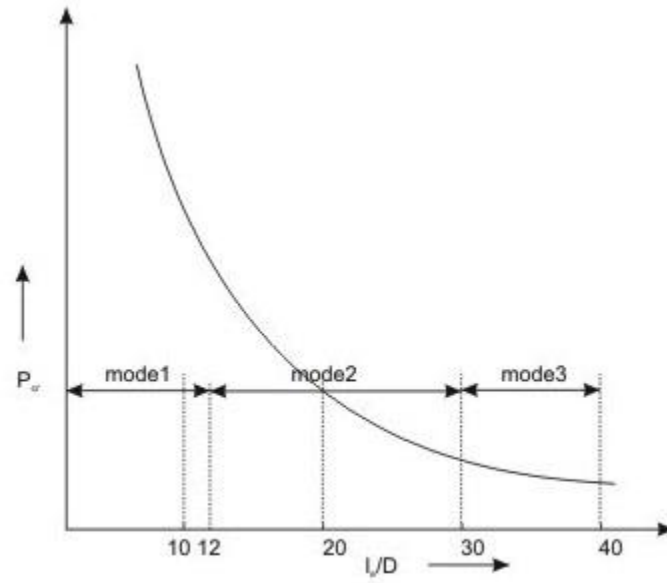

Figure 3.3 Modes of failure of columns

Figure 3.3 presents the three modes of failure of columns with different slenderness ratios when loaded axially. In the mode 1, column does not undergo any lateral deformation and collapses due to material failure. This is known as compression failure. Due to the combined effects of axial load and moment a short column may have material failure of mode 2. On the other hand, a slender column subjected to axial load only undergoes deflection due to beam-column effect and may have material failure under the combined action of direct load and bending moment. Such failure is called combined compression and bending failure of mode 2. Mode 3 failure is by elastic instability of very long column even under small load much before the material reaches the yield stresses. This type of failure is known as elastic buckling.

The slenderness ratio of steel column is the ratio of its effective length l_e to its least radius of gyration r . In case of reinforced concrete column, however, IS 456 stipulates the slenderness ratio as the ratio of its effective length l_e to its least lateral dimension. As mentioned earlier in sec. 3.1(a), the effective length l_e is different from the unsupported length, the rectangular reinforced concrete column of cross-sectional dimensions b and D shall have two effective lengths in the two directions of b and D . Accordingly, the column may have the possibility of buckling depending on the two values of slenderness ratios as given below:

Slenderness ratio about the major axis = l_e / D

Slenderness ratio about the minor axis = l_e / b

Based on the discussion above, cl. 25.1.2 of IS 456 stipulates the following:

A compression member may be considered as short when both the slenderness ratios l_{ex}/D and l_{ey}/b are less than 12 where l_{ex} = effective length in respect of the major axis, D = depth in respect of the major axis, l_{ey} = effective length in respect of the minor axis, and b = width of the member. It shall otherwise be considered as a slender compression member.

Further, it is essential to avoid the mode 3 type of failure of columns so that all columns should have material failure (modes 1 and 2) only. Accordingly, cl. 25.3.1 of IS 456 stipulates the maximum unsupported length between two restraints of a column to sixty times its least lateral dimension. For cantilever columns, when one end of the column is unrestrained, the unsupported length is restricted to $100b^2/D$ where b and D are as defined earlier.

Longitudinal Reinforcement

The longitudinal reinforcing bars carry the compressive loads along with the concrete. Clause 26.5.3.1 stipulates the guidelines regarding the minimum and maximum amount, number of bars, minimum diameter of bars, spacing of bars etc. The following are the salient points:

- (a) The minimum amount of steel should be at least 0.8 per cent of the gross cross-sectional area of the column required if for any reason the provided area is more than the required area.
- (b) The maximum amount of steel should be 4 per cent of the gross cross-sectional area of the column so that it does not exceed 6 per cent when bars from column below have to be lapped with those in the column under consideration.
- (c) Four and six are the minimum number of longitudinal bars in rectangular and circular columns, respectively.
- (d) The diameter of the longitudinal bars should be at least 12 mm.
- (e) Columns having helical reinforcement shall have at least six longitudinal bars within and in contact with the helical reinforcement. The bars shall be placed equidistant around its inner circumference.
- (f) The bars shall be spaced not exceeding 300 mm along the periphery of the column.
- (g) The amount of reinforcement for pedestal shall be at least 0.15 per cent of the cross-sectional area provided.

Transverse Reinforcement

Transverse reinforcing bars are provided in forms of circular rings, polygonal links (lateral ties) with internal angles not exceeding 135° or helical reinforcement. The transverse reinforcing bars are provided to ensure that every longitudinal bar nearest to the compression face has effective lateral support against buckling. Clause 26.5.3.2 stipulates the guidelines of the arrangement of transverse reinforcement. The salient points are:

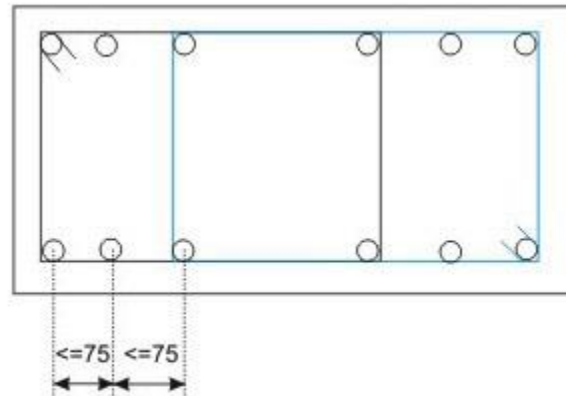

Figure 3.4 Lateral tie (Arrangement 1)

(a) Transverse reinforcement shall only go round corner and alternate bars if the longitudinal bars are not spaced more than 75 mm on either side (Fig.3.4).

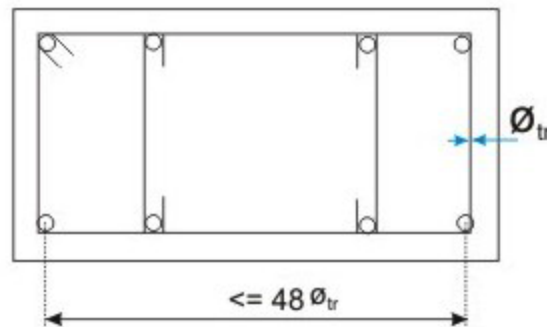

Figure 3.5 Lateral tie (Arrangement 2)

(b) Longitudinal bars spaced at a maximum distance of 48 times the diameter of the tie shall be tied by single tie and additional open ties for in between longitudinal bars (Fig.3.5).

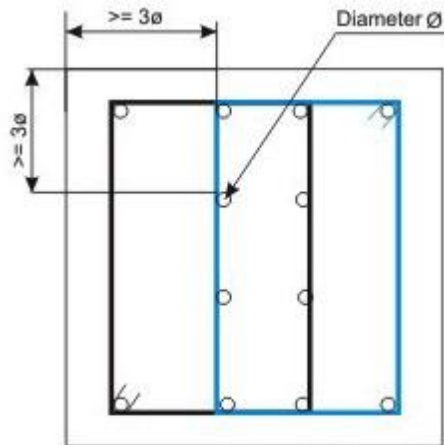

Figure 3.6 Lateral tie (Arrangement 3)

(c) For longitudinal bars placed in more than one row (Fig.10.21.9): (i) transverse reinforcement is provided for the outer-most row in accordance with (a) above, and (ii) no bar of the inner row is closer to the nearest compression face than three times the diameter of the largest bar in the inner row.

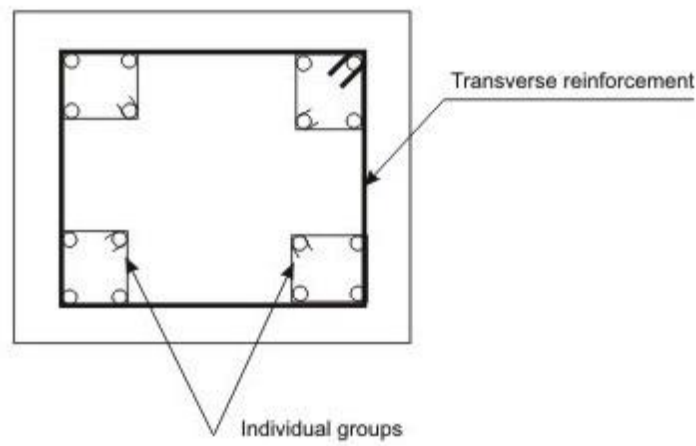

Figure 3.7 Lateral tie (Arrangement 4)

(d) For longitudinal bars arranged in a group such that they are not in contact and each group is adequately tied as per (a), (b) or (c) above, as appropriate, the transverse reinforcement for the compression member as a whole may be provided assuming that each group is a single longitudinal bar for determining the pitch and diameter of the transverse reinforcement. The diameter of such transverse reinforcement should not, however, exceed 20 mm (Fig.3.7).

Pitch and Diameter of Lateral Ties

- (a) Pitch: The maximum pitch of transverse reinforcement shall be the least of the following:
- (i) the least lateral dimension of the compression members;
 - (ii) sixteen times the smallest diameter of the longitudinal reinforcement bar to be tied; and
 - (iii) 300 mm.
- (b) Diameter: The diameter of the polygonal links or lateral ties shall be not less than one-fourth of the diameter of the largest longitudinal bar, and in no case less than 6 mm.

Assumptions in the Design of Compression Members by Limit State of Collapse

The following are the assumptions in addition to given in 38.1 (a) to (e) for flexure for the design of compression members (cl. 39.1 of IS 456).

- (i) The maximum compressive strain in concrete in axial compression is taken as 0.002.
- (ii) The maximum compressive strain at the highly compressed extreme fibre in concrete subjected to axial compression and bending and when there is no tension on the section shall be 0.0035 minus 0.75 times the strain at the least compressed extreme fibre.

Minimum Eccentricity

In practical construction, columns are rarely truly concentric. Even a theoretical column loaded axially will have accidental eccentricity due to inaccuracy in construction or variation of materials etc. Accordingly, all axially loaded columns should be designed considering the minimum eccentricity as stipulated in cl. 25.4 of IS 456 and given below (Fig.3.2c)

$$e_{x \min} \geq \text{greater of } (l/500 + D/30) \text{ or } 20 \text{ mm}$$

$$e_{y \min} \geq \text{greater of } (l/500 + b/30) \text{ or } 20 \text{ mm}$$

where l , D and b are the unsupported length, larger lateral dimension and least lateral dimension, respectively.

Governing Equation for Short Axially Loaded Tied Columns

Factored concentric load applied on short tied columns is resisted by concrete of area A_c and longitudinal steel of areas A_{sc} effectively held by lateral ties at intervals. Assuming the design strengths of concrete and steel are $0.4f_{ck}$ and $0.67f_y$, respectively, we can write

$$P_u = 0.4f_{ck} A_c + 0.67f_y A_{sc} \quad (1)$$

Where P_u = factored axial load on the member,

f_{ck} = characteristic compressive strength of the concrete,

A_c = area of concrete,

f_y = characteristic strength of the compression reinforcement, and

A_{sc} = area of longitudinal reinforcement for columns.

The above equation, given in cl. 39.3 of IS 456, has two unknowns A_c and A_{sc} to be determined from one equation. The equation is recast in terms of A_g , the gross area of concrete and p , the percentage of compression reinforcement employing

$$A_{sc} = pA_g / 100 \quad (2)$$

$$A_c = A_g (1 - p/100) \quad (3)$$

Accordingly, we can write

$$P_u / A_g = 0.4f_{ck} + (p/100) (0.67f_y - 0.4f_{ck}) \quad (4)$$

Equation 4 can be used for direct computation of A_g when P_u , f_{ck} and f_y are known by assuming p ranging from 0.8 to 4 as the minimum and maximum percentages of longitudinal reinforcement. Equation 10.4 also can be employed to determine A_g and p in a similar manner by assuming p .

Numerical Problem

Design the reinforcement in a column of size 400 mm x 600 mm subjected to an axial load of 2000 kN under service dead load and live load. The column has an unsupported length of 4.0 m and effectively held in position and restrained against rotation in both ends. Use M 25 concrete and Fe 415 steel.

Solution

Step 1: To check if the column is short or slender

Given $l = 4000$ mm, $b = 400$ mm and $D = 600$ mm. Table 28 of IS 456 = $l_{ex} = l_{ey} = 0.65(l) = 2600$ mm. So, we have

$$l_{ex} / D = 2600/600 = 4.33 < 12$$

$$l_{ey} / b = 2600/400 = 6.5 < 12$$

Hence, it is a short column.

Step 2: Minimum eccentricity

$$e_{x \min} = \text{Greater of } (l_{ex} / 500 + D/30) \text{ and } 20 \text{ mm} = 25.2 \text{ mm}$$

$$e_{y \min} = \text{Greater of } (l_{ey} / 500 + b/30) \text{ and } 20 \text{ mm} = 20 \text{ mm}$$

$$0.05 D = 0.05(600) = 30 \text{ mm} > 25.2 \text{ mm} (= e_{x \text{ min}})$$

$$0.05 b = 0.05(400) = 20 \text{ mm} = 20 \text{ mm} (= e_{y \text{ min}})$$

Hence, the equation given in cl.39.3 of IS 456 (Eq.(1)) is applicable for the design here.

Step 3: Area of steel

Fro Eq.10.4, we have

$$P_u = 0.4 f_{ck} A_c + 0.67 f_y A_{sc}$$

$$3000(10^3) = 0.4(25)\{(400)(600) - A_{sc}\} + 0.67(415) A_{sc}$$

which gives,

$$A_{sc} = 2238.39 \text{ mm}^2$$

Provide 6-20 mm diameter and 2-16 mm diameter rods giving $2287 \text{ mm}^2 (> 2238.39 \text{ mm}^2)$ and $p = 0.953$ per cent, which is more than minimum percentage of 0.8 and less than maximum percentage of 4.0. Hence, o.k.

Step 4: Lateral ties

The diameter of transverse reinforcement (lateral ties) is determined from cl.26.5.3.2 C-2 of IS 456 as not less than (i) $\phi/4$ and (ii) 6 mm. Here, ϕ = largest bar diameter used as longitudinal reinforcement = 20 mm. So, the diameter of bars used as lateral ties = 6 mm.

The pitch of lateral ties, as per cl.26.5.3.2 C-1 of IS 456, should be not more than the least of

- (i) the least lateral dimension of the column = 400 mm
- (ii) sixteen times the smallest diameter of longitudinal reinforcement bar to be tied =
 $16(16) = 256 \text{ mm}$
- (iii) 300 mm

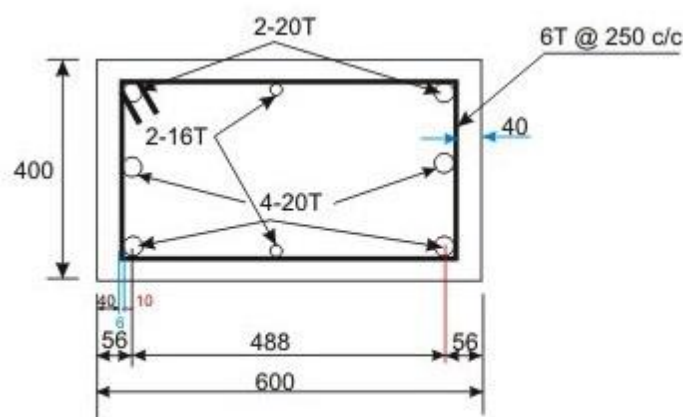

Reinforcement Detailing

Let us use p = pitch of lateral ties = 250 mm.

IS Code Method for Design of Columns under Axial Load and Biaxial Bending

IS 456 recommends the following simplified method, based on Bresler's formulation, for the design of biaxially loaded columns. The relationship between M_{ux} and M_{uy} for a particular value of $P_u = P_{uz}$, expressed in non-dimensional form is:

$$(M_{ux} / M_{ux1})^{\alpha^n} + (M_{uy} / M_{uy1})^{\alpha^n} \leq 1 \quad (5)$$

where M_{ux} and M_{uy} = moments about x and y axes due to design loads, and

α^n is related to P_u / P_{uz} ,

where

$$\begin{aligned} P_{uz} &= 0.45 f_{ck} A_c + 0.75 f_y A_{sc} \\ &= 0.45 A_g + (0.75 f_y - 0.45 f_{ck}) A_{sc} \end{aligned} \quad (6)$$

where A_g = gross area of the section, and

A_{sc} = total area of steel in the section

M_{uxz} , M_{uyz} , M_{ux1} and M_{uy1} are explained earlier.

$$\alpha^n = 1.0, \text{ when } P_u / P_{uz} \leq 0.2$$

$$\alpha^n = 0.67 + 1.67 P_u / P_{uz}, \text{ when } 0.2 < (P_u / P_{uz}) < 0.8 \quad (7)$$

$$\alpha^n = 2.0, \text{ when } (P_u / P_{uz}) \geq 0.8$$

Numerical Problem

Design the reinforcement to be provided in the short column is subjected to $P_u = 2000$ kN, $M_{ux} = 130$ kNm (about the major principal axis) and $M_{uy} = 120$ kNm (about the minor principal axis). The unsupported length of the column is 3.2 m, width $b = 400$ mm and depth $D = 500$ mm. Use M 25 and Fe 415 for the design.

Solution

Step 1: Verification of the eccentricities

Given: $l = 3200$ mm, $b = 400$ mm and $D = 500$ mm,

The minimum eccentricities are:

$$e_{x\min} = \text{greater of } (3200/500 + 400/30) \text{ and } 20 \text{ mm} = 19.73 \text{ mm or } 20 \text{ mm} = 20 \text{ mm}$$

$$e_{y\min} = \text{greater of } (3200/500 + 500/30) \text{ and } 20 \text{ mm} = 23.07 \text{ mm or } 20 \text{ mm} = 23.07 \text{ mm}$$

Again from $P_u = 2000$ kN, $M_{ux} = 130$ kNm and $M_{uy} = 120$ kNm, we have $e_x = M_{ux}/P_u = 130(10^6)/2000(10^3) = 65$ mm and $e_y = M_{uy}/P_u = 120(10^6)/2000(10^3) = 60$ mm. Both e_x and e_y are greater than e_{xmin} and e_{ymin} , respectively.

Step 2: Assuming a trial section including the reinforcement

We have $b = 400$ mm and $D = 500$ mm. For the reinforcement, $M_u = 1.15(M_{ux}^2 + M_{uy}^2)$, becomes 203.456 kNm. Accordingly,

$$P_u/f_{ck} bD = 2000(10^3)/(25)(400)(500) = 0.4$$

$$M_u/f_{ck} bD^2 = 203.456(10^6)/(25)(400)(500)(500) = 0.0814$$

Assuming $d' = 60$ mm, we have $d'/D = 0.12$. From Charts 44 and 45, the value of p/f_{ck} is interpolated as 0.06. Thus, $p = 0.06(25) = 1.5$ per cent, giving $A_{sc} = 3000$ mm². Provide 12-20 mm diameter bars of area 3769 mm², actual p provided = 1.8845 per cent. So, $p/f_{ck} = 0.07538$.

Step 3: Determination of M_{ux1} and M_{uy1}

We have $P_u/f_{ck} bD = 0.4$ and $p/f_{ck} = 0.07538$ in step 2. Now, we get $M_{ux1}/f_{ck} bD^2$ from chart corresponding to $d' = 58$ mm i.e., $d'/D = 0.116$. We interpolate the values of Charts 44 and 45, and get $M_{ux1}/f_{ck} bD^2 = 0.09044$. So, $M_{ux1} = 0.0944(25)(400)(500)(500)(10^{-6}) = 226.1$ kNm.

For M_{ux1} , $d'/b = 58/400 = 0.145$. In a similar manner, we get $M_{uy1} = 0.0858(25)(400)(400)(500)(10^{-6}) = 171.6$ kNm.

As M_{ux1} and M_{uy1} are significantly greater than M_{ux} and M_{uy} , respectively, redesign of the section is not needed.

Step 4: Determination of P_{uz} and α^n

We have $P_{uz} = 0.45(25)(400)(500) + \{0.75(415) - 0.45(25)\}(3769) = 3380.7$ kN.

Now, the value of α^n is obtained for $P_u/P_{uz} = 2000/3380.7 = 0.5916$, i.e., $0.2 < P_u/P_{uz} < 0.8$, which gives, $n\alpha = 0.67 + 1.67(P_u/P_{uz}) = 1.658$.

Step 5: Checking the adequacy of the section

Using the values of M_{ux} , M_{ux1} , M_{uy} , M_{uy1} and α^n in Eq.(5), we have $(130/226.1)^{1.658} + (120/171.6)^{1.658} = 0.9521 < 1.0$. Hence, the design is safe.

Step 6: Design of transverse reinforcement

As per cl.26.5.3.2c of IS 456, the diameter of lateral tie should be $> (20/4)$ mm diameter. Provide 8 mm diameter bars following the arrangement shown in Fig.10.26.4. The spacing of lateral tie is the least of:

- (a) 400 mm = least lateral dimension of column,
- (b) 320 mm = sixteen times the diameter of longitudinal reinforcement (20 mm),
- (c) 300 mm

Accordingly, provide 8 mm lateral tie alternately @ 250 c/c (Fig.10.26.4).

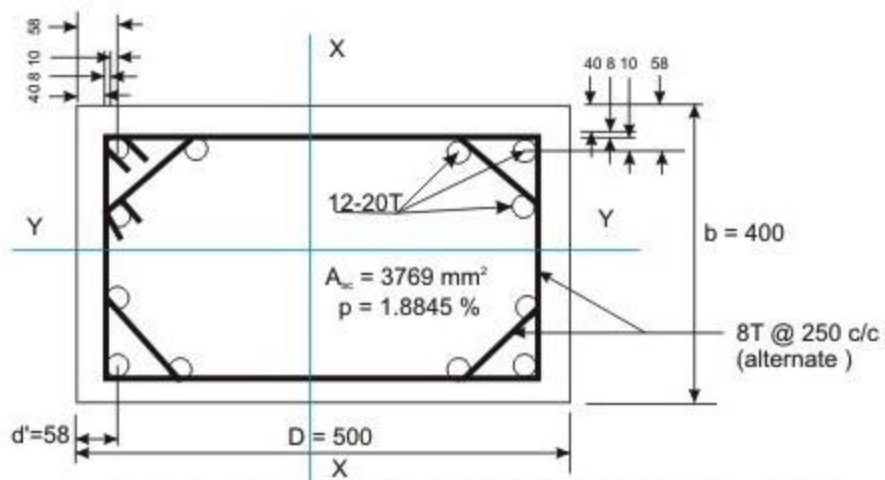

Reinforcement Detailing

Slender Columns

Columns having both l_{ex}/D and l_{ey}/b less than twelve are designated as short and otherwise, they are slender, where l_{ex} and l_{ey} are the effective lengths with respect to major and minor axes, respectively; and D and b are the depth and width of rectangular columns, respectively.

Design of Slender Columns

The design of slender compression members shall be based on the forces and the moments determined from an analysis of the structure, including the effect of deflections on moments and forces. When the effect of deflections are not taken into account in the analysis, additional moment given in cl no 39.7.1 of IS 456:2000 shall be taken into account in the appropriate direction.

The additional moments M_x and M_y , shall be calculated by the following formulae:

$$M_x = (P_u D/2000) (l_{ex}/D)^2$$

$$M_y = (P_u b/2000) (l_{ey}/b)^2$$

Where P_u = axial load on the member,

l_{ex} = effective length in respect of the major axis,

l_{ey} = effective length in respect of the minor axis,

D = depth of the cross-section at right angles to the major axis, and

b = width of the member.

The values given by equation 39.7.1 may be multiplied by the following factor:

(i) For $P_u > P_{ubx}$: $k_x = (P_{uz} - P_u)/(P_{uz} - P_{ubx})$

(ii) For $P_u > P_{uby}$: $k_y = (P_{uz} - P_u)/(P_{uz} - P_{uby})$

with a condition that k_x and k_y should be ≤ 1

where P_u = axial load on compression member

$$P_{uz} = 0.45 f_{ck} A_c + 0.75 f_y A_{st}$$

P_{ubx} , P_{uby} = axial loads with respect to major and minor axes, respectively, corresponding to the condition of maximum compressive strain of 0.0035 in concrete and tensile strain of 0.002 in outermost layer of tension steel.

Numerical Problem

Determine the reinforcement required for a braced column against sidesway with the following data: size of the column = 350 x 450 mm (Fig.10.27.18); concrete and steel grades

= M 30 and Fe 415, respectively; effective lengths l_{ex} and l_{ey} = 7.0 and 6.0 m, respectively; unsupported length l = 8 m; factored load P_u = 1700 kN; factored moments in the direction of larger dimension = 70 kNm at top and 30 kNm at bottom; factored moments in the direction of shorter dimension = 60 kNm at top and 30 kNm at bottom. The column is bent in double curvature. Reinforcement will be distributed equally on four sides.

Solution

Solution 1:

Step 1: Checking of slenderness ratios

$$l_{ex}/D = 7000/450 = 15.56 > 12,$$

$$l_{ey}/b = 6000/350 = 17.14 > 12.$$

Hence, the column is slender with respect to both the axes.

Step 2: Minimum eccentricities and moments due to minimum eccentricities

$$e_{x\min} = l/500 + D/30 = 8000/500 + 450/30 = 31.0 > 20 \text{ mm}$$

$$e_{y\min} = l/500 + b/30 = 8000/500 + 350/30 = 27.67 > 20 \text{ mm}$$

$$M_{ox} (\text{Min. ecc.}) = P_u (e_{x\min}) = (1700) (31) (10^{-3}) = 52.7 \text{ kNm}$$

$$M_{oy} (\text{Min. ecc.}) = P_u (e_{y\min}) = (1700) (27.67) (10^{-3}) = 47.04 \text{ kNm}$$

Step 3: Additional eccentricities and additional moments

Table I of SP-16

For $l_{ex}/D = 15.56$, Table I of SP-16 gives:

$$e_{ax}/D = 0.1214, \text{ which gives } e_{ax} = (0.1214) (450) = 54.63 \text{ mm}$$

For $l_{ey}/b = 17.14$, Table I of SP-16 gives:

$$e_{ay}/b = 0.14738, \text{ which gives } e_{ay} = (0.14738) (350) = 51.583 \text{ mm}$$

Step 4: Primary moments and primary eccentricities (Eqs.10.88 and 89)

$$M_{ox} = 0.6M_2 - 0.4M_1 = 0.6(70) - 0.4(30) = 30 \text{ kNm, which should be } \geq 0.4 M_2 (= 28 \text{ kNm}).$$

Hence, o.k.

$$M_{oy} = 0.6M_2 - 0.4M_1 = 0.6(60) - 0.4(30) = 24 \text{ kNm, which should be } \geq 0.4 M_2 (= 24$$

kNm). Hence, o.k.

Primary eccentricities:

$$e_x = M_{ox}/P_u = (30/1700) (10^3) = 17.65 \text{ mm}$$

$$e_y = M_{oy} / P_u = (24/1700) (10^3) = 14.12 \text{ mm}$$

Since, both primary eccentricities are less than the respective minimum eccentricities (see Step 2), the primary moments are revised to those of Step 2. So, $M_{ox} = 52.7 \text{ kNm}$ and $M_{oy} = 47.04 \text{ kNm}$.

Step 5: Modification factors

To determine the actual modification factors, the percentage of longitudinal reinforcement should be known. So, either the percentage of longitudinal reinforcement may be assumed or the modification factor may be assumed which should be verified subsequently. So, we assume the modification factors of 0.55 in both directions.

Step 6: Total factored moments

$$M_{ux} = M_{ox} + (\text{Modification factor}) (M_{ax}) = 52.7 + (0.55) (92.548) \\ = 52.7 + 50.9 = 103.6 \text{ kNm}$$

$$M_{uy} = M_{oy} + (\text{Modification factor}) (M_{ay}) = 47.04 + (0.55) (87.43) \\ = 47.04 + 48.09 = 95.13 \text{ kNm}$$

Step 7: Trial section

The trial section is determined from the design of uniaxial bending with $P_u = 1700 \text{ kN}$ and $M_u = 1.15(M_{ux}^2 + M_{uy}^2)^{1/2}$. So, we have $M_u = (1.15)\{(103.6)^2 + (95.13)^2\}^{1/2} = 161.75 \text{ kNm}$. With these values of $P_u (= 1700 \text{ kN})$ and $M_u (= 161.75 \text{ kNm})$, we use chart of SP-16 for the $Dd'/b = 0.134$. We assume the diameters of longitudinal bar as 25 mm, diameter of lateral tie = 8 mm and cover = 40 mm, to get $d = 40 + 8 + 12.5 = 60.5 \text{ mm}$. Accordingly, $d'/D = 60.5/450 = 0.134$ and $d'/b = 60.5/350 = 0.173$.

$$P_u / f_{ck} bD = 1700(10^3) / (30)(350)(450) = 0.3598$$

$$M_u / f_{ck} bD^2 = 161.75(10^6) / (30)(350)(450)(450) = 0.076$$

We have to interpolate the values of p/f_{ck} for $d'/D = 0.134$ obtained from Charts 44 (for $d'/D = 0.1$) and 45 ($d'/D = 0.15$). The values of p/f_{ck} are 0.05 and 0.06 from Charts 44 and 45, respectively. The corresponding values of p are 1.5 and 1.8 per cent, respectively. The interpolated value of p for $d'/D = 0.134$ is 1.704 per cent, which gives $A_{sc} = (1.704)(350)(450)/100 = 2683.8 \text{ mm}^2$. We use 4-25 + 4-20 ($1963 + 1256 = 3219 \text{ mm}^2$), to have p provided = 2.044 per cent giving $p/f_{ck} = 0.068$.

Step 8: Calculation of balanced loads P_b

The values of P_{bx} and P_{by} are determined using Table 60 of SP-16. For this purpose, two parameters k_1 and k_2 are to be determined first from the table. We have $p/f_{ck} = 0.068$, $d'/D = 0.134$ and $d'/b = 0.173$. From Table 60, $k_1 = 0.19952$ and $k_2 = 0.243$ (interpolated for $d'/D = 0.134$) for P_{bx} . So, we have: $P_{bx}/f_{ck} bD = k_1 + k_2 (p/f_{ck}) = 0.19952 + 0.243(0.068) = 0.216044$, which gives $P_{bx} = 0.216044(30)(350)(450)(10^{-3}) = 1020.81$ kN.

Similarly, for P_{by} : $d'/D = 0.173$, $p/f_{ck} = 0.068$. From Table 60 of SP-16, $k_1 = 0.19048$ and $k_2 = 0.1225$ (interpolated for $d'/b = 0.173$). This gives $P_{by}/f_{ck} bD = 0.19048 + 0.1225(0.068) = 0.19881$, which gives $P_{by} = (0.19881)(30)(350)(450)(10^{-3}) = 939.38$ kN.

Since, the values of P_{bx} and P_{by} are less than P_u , the modification factors are to be used.

Step 9: Determination of P_{uz} **Method 1: From Eq.10.59 of Lesson 26**

$$P_{uz} = 0.45 f_{ck} A_g + (0.75 f_y - 0.45 f_{ck}) A_{sc}$$

$$= 0.45(30)(350)(450) + \{0.75(415) - 0.45(30)\}(3219) = 3084.71 \text{ kN}$$

Step 10: Determination of modification factors

$$k_{ax} = (P_{uz} - P_u) / (P_{uz} - P_{ubx})$$

$$\text{or } k_{ax} = (3084.71 - 1700) / (3084.71 - 1020.81) = 0.671 \text{ and}$$

$$k_{ay} = (P_{uz} - P_u) / (P_{uz} - P_{uby})$$

$$\text{or } k_{ay} = (3084.71 - 1700) / (3084.71 - 939.39) = 0.645$$

The values of the two modification factors are different from the assumed value of 0.55 in Step 5. However, the moments are changed and the section is checked for safety.

Step 11: Total moments incorporating modification factors

$$M_{ux} = M_{ox} \text{ (from Step 4)} + (k_{ax}) M_{ax} \text{ (from Step 3)}$$

$$= 52.7 + 0.671(92.548) = 114.8 \text{ kNm}$$

$$M_{uy} = M_{oy} \text{ (from Step 4)} + k_{ay} (M_{ay}) \text{ (from Step 3)}$$

$$= 47.04 + (0.645)(87.43) = 103.43 \text{ kNm.}$$

Step 12: Uniaxial moment capacities

The two uniaxial moment capacities M_{ux1} and M_{uy1} are determined as stated: (i) For M_{ux1} , by interpolating the values obtained from Charts 44 and 45, knowing the values of $P_u/f_{ck}bD = 0.3598$ (see Step 7), $p/f_{ck} = 0.068$ (see Step 7), $d'/D = 0.134$ (see Step 7), (ii) for M_{uy1} , by interpolating the values obtained from Charts 45 and 46, knowing the same values of $P_u/f_{ck}bD$ and p/f_{ck} as those of (i) and $d'/D = 0.173$ (see Step 7). The results are given below:

$$(i) M_{ux1}/f_{ck}bD^2 = 0.0882 \text{ (interpolated between 0.095 and 0.085)}$$

$$(ii) M_{uy1}/f_{ck}bb^2 = 0.0827 \text{ (interpolated between 0.085 and 0.08)}$$

So, we have, $M_{ux1} = 187.54$ kNm and $M_{uy1} = 136.76$ kNm.

Step 13: Value of α^n

We have $P_u/P_{uz} = 1700/3084.71 = 0.5511$. We have $\alpha^n = 0.67 + 1.67(P_u/P_{uz}) = 1.59$.

Step 14: Checking of column for safety

$$(M_{ux}/M_{ux1})^{\alpha^n} + (M_{uy}/M_{uy1})^{\alpha^n} \leq 1$$

Here, putting the values of M_{ux} , M_{ux1} , M_{uy} , M_{uy1} and α^n , we get: $(114.8/187.54)^{1.5452} + (103.43/136.76)^{1.5852} = 0.4593 + 0.6422 = 1.1015$. Hence, the section or the reinforcement has to be revised.

Step R9: Determination of P_{uz}

$$P_{uz} = 0.45(30)(350)(450) + \{0.75(415) - 0.45(30)\}(3927) = 3295.514 \text{ kN.}$$

Step R10: Determination of modification factors

$$k_{ax} = (3295.514 - 1700)/(3295.514 - 1038.145) = 0.707$$

$$k_{ay} = (3295.514 - 1700)/(3295.514 - 948.12) = 0.68$$

Step R11: Total moments incorporating modification factors

$$M_{ux} = 52.70 + 0.707(92.548) = 118.13 \text{ kNm}$$

$$M_{uy} = 47.04 + 0.68(87.43) = 106.49 \text{ kNm}$$

Step R12: Uniaxial moment capacities

Using Charts 44 and 45 for M_{ux1} and Charts 45 and 46 for M_{uy1} , we get (i) the coefficient 0.1032 (interpolating 0.11 and 0.10) and (ii) the coefficient 0.0954 (interpolating 0.1 and 0.09) for M_{ux1} and M_{uy1} , respectively.

$$M_{ux1} = (0.1032)(30)(350)(450)(450)(10^{-6}) = 219.429 \text{ kNm}$$

$$M_{uy1} = (0.0954)(30)(450)(350)(350)(10^{-6}) = 157.77 \text{ kNm}$$

Step R13: Value of α^n

$$P_u/P_{uz} = 1700/3295.514 = 0.5158 \text{ which gives}$$

$$n\alpha = 1 + (0.5158 - 0.2)/0.6 = 1.5263$$

Step R14: Checking of column for safety

$$(118.13/219.424)^{1.5263} + (106.49/157.77)^{1.5263} = 0.3886 + 0.5488 = 0.9374 < 1.0$$

Hence, the revised reinforcement is safe.

Design of Footings (LSM)

Design of isolated column footing.

The superstructure is placed on the top of the foundation structure, designated as substructure as they are placed below the ground level. The elements of the superstructure transfer the loads and moments to its adjacent element below it and finally all loads and moments come to the foundation structure, which in turn, transfers them to the underlying soil or rock. Thus, the foundation structure effectively supports the superstructure. However, all types of soil get compressed significantly and cause the structure to settle. Accordingly, the major requirements of the design of foundation structures are the two as given below (see cl.34.1 of IS 456):

1. Foundation structures should be able to sustain the applied loads, moments, forces and induced reactions without exceeding the safe bearing capacity of the soil.
2. The settlement of the structure should be as uniform as possible and it should be within the tolerable limits. It is well known from the structural analysis that differential settlement of supports causes additional moments in statically indeterminate structures. Therefore, avoiding the differential settlement is considered as more important than maintaining uniform overall settlement of the structure.

Types of Foundation Structures

1. Shallow Foundation

Shallow foundations are used when the soil has sufficient strength within a short depth below the ground level. They need sufficient plan area to transfer the heavy loads to the base soil. These heavy loads are sustained by the reinforced concrete columns or walls (either of bricks or reinforced concrete) of much less areas of cross-section due to high strength of bricks or reinforced concrete when compared to that of soil. The strength of the soil, expressed as the safe bearing capacity of the soil is normally supplied by the geotechnical experts to the structural engineer. Shallow foundations are also designated as footings. The different types of shallow foundations or footings are discussed below.

- (i) Plain concrete pedestal footings
- (ii) Isolated footings
- (iii) Combined footings
- (iv) Strap footings
- (v) Strip foundation or wall footings
- (vi) Raft or mat foundation

2. Deep foundations

As mentioned earlier, the shallow foundations need more plan areas due to the low strength of soil compared to that of masonry or reinforced concrete. However, shallow foundations are selected when the soil has moderately good strength, except the raft foundation which is good in poor condition of soil also. Raft foundations are under the category of shallow foundation as they have comparatively shallow depth than that of deep foundation. It is worth mentioning that the depth of raft foundation is much larger than those of other types of shallow foundations.

However, for poor condition of soil near to the surface, the bearing capacity is very less and foundation needed in such situation is the pile foundation. Piles are, in fact, small diameter columns which are driven or cast into the ground by suitable means. Precast piles are driven and cast-in-situ are cast. These piles support the structure by the skin friction between the pile surface and the surrounding soil and end bearing force, if such resistance is available to provide the bearing force. Accordingly, they are designated as frictional and end bearing piles. They are normally provided in a group with a pile cap at the top through which the loads of the superstructure are transferred to the piles.

Piles are very useful in marshy land where other types of foundation are impossible to construct. The length of the pile which is driven into the ground depends on the availability of hard soil/rock or the actual load test. Another advantage of the pile foundations is that they can resist uplift also in the same manner as they take the compression forces just by the skin friction in the opposite direction.

However, driving of pile is not an easy job and needs equipment and specially trained persons or agencies. Moreover, one has to select pile foundation in such a situation where the adjacent buildings are not likely to be damaged due to the driving of piles. The choice of driven or bored piles, in this regard, is critical.

Exhaustive designs of all types of foundations mentioned above are beyond the scope of this course. Accordingly, this module is restricted to the design of some of the shallow footings, frequently used for normal low rise buildings only.

Isolated Footing

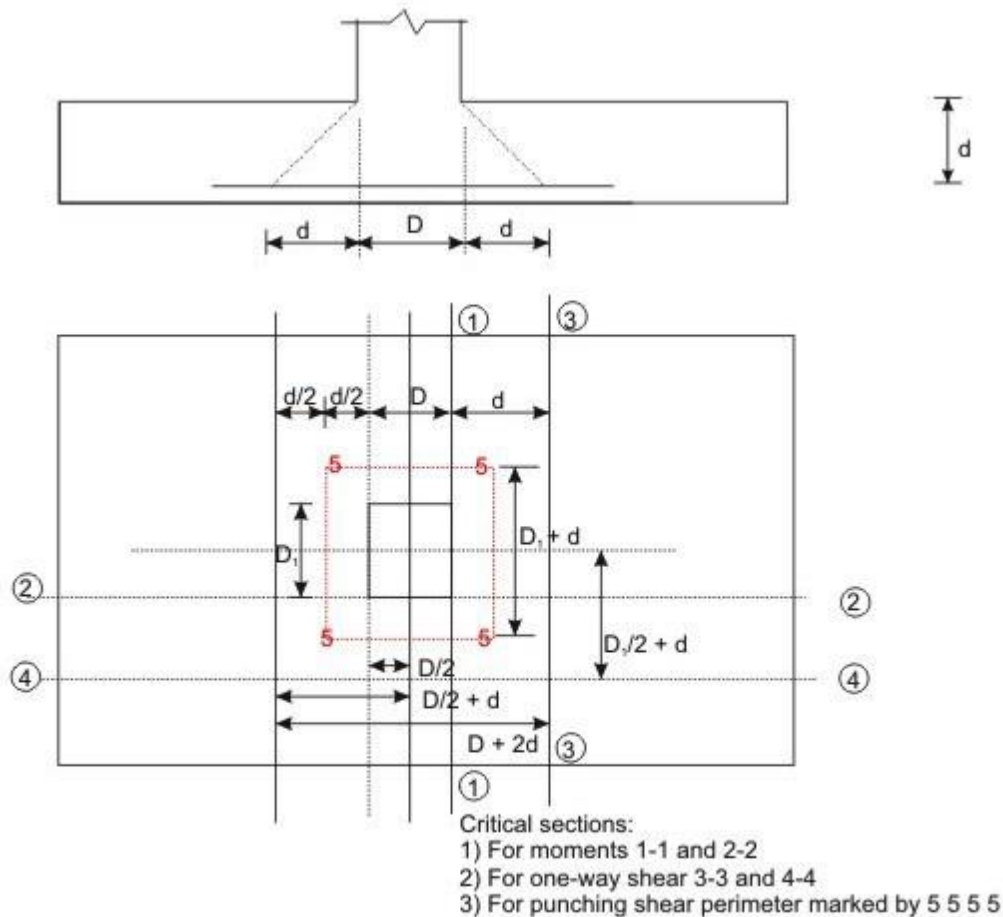

Figure 3.8: Uniform and rectangular footing

Design Considerations

(a) Minimum nominal cover (cl. 26.4.2.2 of IS 456)

The minimum nominal cover for the footings should be more than that of other structural elements of the superstructure as the footings are in direct contact with the soil. Clause 26.4.2.2 of IS 456 prescribes a minimum cover of 50 mm for footings. However, the actual cover may be even more depending on the presence of harmful chemicals or minerals, water table etc.

(b) Thickness at the edge of footings (cls. 34.1.2 and 34.1.3 of IS 456)

The minimum thickness at the edge of reinforced and plain concrete footings shall be at least 150 mm for footings on soils and at least 300 mm above the top of piles for footings on piles, as per the stipulation in cl.34.1.2 of IS 456.

For plain concrete pedestals, the angle α (see Fig.11.28.1) between the plane passing through the bottom edge of the pedestal and the corresponding junction edge of the column with pedestal and the horizontal plane shall be determined from the following expression (cl.34.1.3 of IS 456)

$$\tan \alpha \leq 0.9\{(100q_a / f_{ck}) + 1\}^{0.5}$$

where q_a = calculated maximum bearing pressure at the base of pedestal in N/mm^2 , and

f_{ck} = characteristic strength of concrete at 28 days in N/mm^2 .

(c) Bending moments (cl. 34.2 of IS 456)

1. It may be necessary to compute the bending moment at several sections of the footing depending on the type of footing, nature of loads and the distribution of pressure at the base of the footing. However, bending moment at any section shall be determined taking all forces acting over the entire area on one side of the section of the footing, which is obtained by passing a vertical plane at that section extending across the footing (cl.34.2.3.1 of IS 456).

2. The critical section of maximum bending moment for the purpose of designing an isolated concrete footing which supports a column, pedestal or wall shall be:

(i) at the face of the column, pedestal or wall for footing supporting a concrete column, pedestal or reinforced concrete wall, and

(ii) halfway between the centre-line and the edge of the wall, for footing under masonry wall.

This is stipulated in cl.34.2.3.2 of IS 456.

The maximum moment at the critical section shall be determined as mentioned in 1 above.

For round or octagonal concrete column or pedestal, the face of the column or pedestal shall be taken as the side of a square inscribed within the perimeter of the round or octagonal column or pedestal (see cl.34.2.2 of IS 456 and Figs.11.28.13a and b).

(d) Shear force (cl. 31.6 and 34.2.4 of IS 456)

Footing slabs shall be checked in one-way or two-way shears depending on the nature of bending. If the slab bends primarily in one-way, the footing slab shall be checked in one-way vertical shear. On the other hand, when the bending is primarily two-way, the footing slab shall be checked in two-way shear or punching shear. The respective critical sections and design shear strengths are given below:

1. One-way shear (cl. 34.2.4 of IS 456)

One-way shear has to be checked across the full width of the base slab on a vertical section located from the face of the column, pedestal or wall at a distance equal to

- (i) effective depth of the footing slab in case of footing slab on soil, and
- (ii) half the effective depth of the footing slab if the footing slab is on piles.

The design shear strength of concrete without shear reinforcement is given in Table 19 of cl.40.2 of IS 456.

2. Two-way or punching shear (cls.31.6 and 34.2.4)

Two-way or punching shear shall be checked around the column on a perimeter half the effective depth of the footing slab away from the face of the column or pedestal.

The permissible shear stress, when shear reinforcement is not provided, shall not exceed $k_s \tau_c$, where $k_s = (0.5 + c\beta)$, but not greater than one, $c\beta$ being the ratio of short side to long side of the column, and $\tau_c = 0.25(f_{ck})^{1/2}$ in limit state method of design, as stipulated in cl.31.6.3 of IS 456.

Normally, the thickness of the base slab is governed by shear. Hence, the necessary thickness of the slab has to be provided to avoid shear reinforcement.

(e) Bond (cl.34.2.4.3 of IS 456)

The critical section for checking the development length in a footing slab shall be the same planes as those of bending moments in part (c) of this section. Moreover, development length shall be checked at all other sections where they change abruptly. The critical sections for checking the development length are given in cl.34.2.4.3 of IS 456, which further recommends to check the anchorage requirements if the reinforcement is curtailed, which shall be done in accordance with cl.26.2.3 of IS 456.

(f) Tensile reinforcement (cl.34.3 of IS 456)

The distribution of the total tensile reinforcement, calculated in accordance with the moment at critical sections, as specified in part (c) of this section, shall be done as given below for one-way and two-way footing slabs separately.

- (i) In one-way reinforced footing slabs like wall footings, the reinforcement shall be distributed uniformly across the full width of the footing i.e., perpendicular to the direction of wall. Nominal distribution reinforcement shall be provided as per cl. 34.5 of IS 456 along the length of the wall to take care of the secondary moment, differential settlement, shrinkage and temperature effects.
- (ii) In two-way reinforced square footing slabs, the reinforcement extending in each direction shall be distributed uniformly across the full width/length of the footing.

(iii) In two-way reinforced rectangular footing slabs, the reinforcement in the long direction shall be distributed uniformly across the full width of the footing slab. In the short direction, a central band equal to the width of the footing shall be marked along the length of the footing, where the portion of the reinforcement shall be determined as given in the equation below. This portion of the reinforcement shall be distributed across the central band:

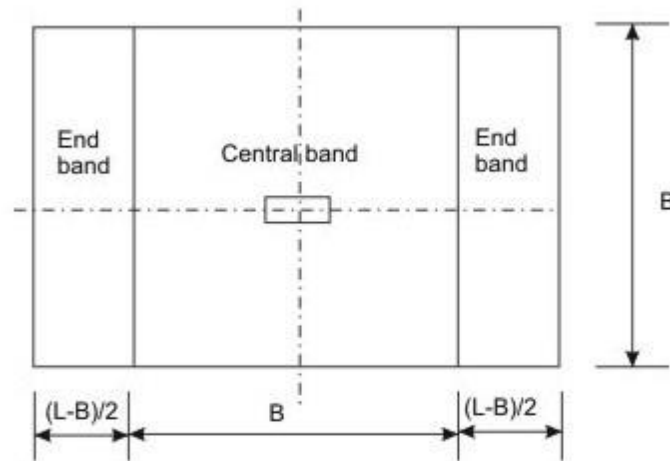

Figure 3.10 Bands for reinforcement in rectangular footing

Reinforcement in the central band = $\{2/(\beta+1)\}$ (Total reinforcement in the short direction)

Where β is the ratio of longer dimension to shorter dimension of the footing slab (Fig.3.10).

Each of the two end bands shall be provided with half of the remaining reinforcement, distributed uniformly across the respective end band.

(g) Transfer of load at the base of column (cl.34.4 of IS 456)

All forces and moments acting at the base of the column must be transferred to the pedestal, if any, and then from the base of the pedestal to the footing, (or directly from the base of the column to the footing if there is no pedestal) by compression in concrete and steel and tension in steel. Compression forces are transferred through direct bearing while tension forces are transferred through developed reinforcement. The permissible bearing stresses on full area of concrete shall be taken as given below from cl.34.4 of IS 456:

$$\sigma_{br} = 0.25f_{ck}, \text{ in working stress method, and}$$

$$\sigma_{br} = 0.45f_{ck}, \text{ in limit state method}$$

The stress of concrete is taken as $0.45f_{ck}$ while designing the column. Since the area of footing is much larger, this bearing stress of concrete in column may be increased

considering the dispersion of the concentrated load of column to footing. Accordingly, the permissible bearing stress of concrete in footing is given by (cl.34.4 of IS 456):

$$\sigma_{br} = 0.45f_{ck} (A_1/A_2)^{1/2}$$

with a condition that

$$(A_1/A_2)^{1/2} \leq 2.0 \quad (11.8) \leq 2$$

where A_1 = maximum supporting area of footing for bearing which is geometrically similar to and concentric with the loaded area A_2 .

A_2 = loaded area at the base of the column.

The above clause further stipulates that in sloped or stepped footings, A_1 may be taken as the area of the lower base of the largest frustum of a pyramid or cone contained wholly within the footing and having for its upper base, the area actually loaded and having side slope of one vertical to two horizontal.

If the permissible bearing stress on concrete in column or in footing is exceeded, reinforcement shall be provided for developing the excess force (cl.34.4.1 of IS 456), either by extending the longitudinal bars of columns into the footing (cl.34.4.2 of IS 456) or by providing dowels as stipulated in cl.34.4.3 of IS 456 and given below:

- (i) Sufficient development length of the reinforcement shall be provided to transfer the compression or tension to the supporting member in accordance with cl.26.2 of IS 456, when transfer of force is accomplished by reinforcement of column (cl.34.4.2 of IS 456).
- (ii) Minimum area of extended longitudinal bars or dowels shall be 0.5 per cent of the cross-sectional area of the supported column or pedestal (cl.34.4.3 of IS 456).
- (iii) A minimum of four bars shall be provided (cl.34.4.3 of IS 456).
- (iv) The diameter of dowels shall not exceed the diameter of column bars by more than 3 mm.
- (v) Column bars of diameter larger than 36 mm, in compression only can be doweled at the footings with bars of smaller size of the necessary area. The dowel shall extend into the column, a distance equal to the development length of the column bar and into the footing, a distance equal to the development length of the dowel, as stipulated in cl.34.4.4 of IS 456.

(h) Nominal reinforcement (cl. 34.5 of IS 456)

Clause 34.5.1 of IS 456 stipulates the minimum reinforcement and spacing of the bars in footing slabs as per the requirements of solid slab (cls.26.5.2.1 and 26.3.3b(2) of IS 456, respectively).

Numerical Problem

Design an isolated footing of uniform thickness of a RC column bearing a vertical load of 600 KN and having a base of size 500x500 mm. the safe bearing capacity of soil may be taken as 120 KN/m². Use M20 concrete and Fe 415 steel.

Solution

Size of footing

W=600 KN;

Self weight of footing @ 10% =60 KN

Total load =660 KN

Size of footing = 660/120 = 5.5 m²

Since square footing , B= $\sqrt{5.5}$ =2.345 m²

Provide a square footing = 2.4mx 2.4m

Net upward pressure , p₀= 600/(2.4x2.4) = 104.17 KN/m²

Design of section

The maximum BM acts at the face of column

$$M = p_o \frac{B}{8} (B - b)^2 = 112.8 \text{ KN} - \text{m}$$

M_u = 1.5M =169.2 KN-m

Therefore d = 160 mm; D = 160+60 = 220mm

Depth on the basis of one-way shear

For a one way shear, critical section is located at a distance 'd' from the face of the column where shear force V is given by

$$V = p_o B \{0.5(B - b) - d\} = 104.17 \times 2.4 \{0.5 \times (2.4 - 0.5) - 0.001d\}$$

$$V_u = 1.5V$$

$$\tau_c = \frac{V_u}{bd} = \frac{375012(0.95 - 0.001d)}{2400d}$$

From table B.5.2.1.1 of IS 456:2000 $k=1.16$ for $D = 220\text{mm}$.

Also for under-reinforced section with $p_t = 0.3\%$ for M20 concrete, $\tau_c = 0.384 \text{ N/mm}^2$.

Hence design shear stress = $k \tau_c = 0.445 \text{ N/mm}^2$

From which we get $d = 246.7 \approx 250 \text{ mm}$

Depth for two way shear

Take d greater one of the two i.e. 250mm . for two-way shear, the section lies at $d/2$ from the column face all round. The width b_o of the section = $b+d = 750\text{mm}$

Shear force around the section

$$F = p_o [B^2 - b_o^2] = 541.42 \text{ KN}$$

$$F_u = 1.5F$$

$$\tau_v = \frac{F_u}{4b_o d} = \frac{812.13 \times 10^6}{4 \times 750 \times 250} = 1.083 \text{ N/mm}^2$$

Permissible shear stress = $k_s \tau_c$

Where $k_s = (0.5 + \beta_c) = (0.5 + 1)$ with a maximum value 1. $k_s = 1$

$$\tau_c = 0.25 \sqrt{f_{ck}} = 1.118 \text{ N/mm}^2$$

Permissible shear stress = 1.118 N/mm^2

Hence safe.

Hence $d = 250 \text{ mm}$, using 60 mm as effective cover and keeping $D = 330 \text{ mm}$, effective depth = $330 - 60 = 270 \text{ mm}$ in one direction and other direction $d = 270 - 12 = 258 \text{ mm}$.

Calculation of reinforcement

$$A_{st} = 1944 \text{ mm}^2$$

Using 12 mm bars, spacing required = 138.27 mm

So provide 12 mm @ 125 c/c in each direction.

Development length

$$L_d = 564 \text{ mm}$$

Provide 60 mm side cover, length of bars available = $0.5[B-b]-60 = 890 \text{ mm} > L_d$

So safe.

Transfer of load at column base

$$A_2 = 500 \times 500 = 250000 \text{ mm}^2$$

$$A_1 = [500 + 2(2 \times 330)]^2 = 3312400 \text{ mm}^2$$

$$\sqrt{\frac{A_1}{A_2}} = 3.64$$

$$\text{Taking } \sqrt{\frac{A_1}{A_2}} = 2$$

Hence permissible bearing stress = 18 KN/m^2

Actual bearing stress = 3.6 N/mm^2

Hence safe.